



FLASH MOBILE

Operating Manual

Translation of original instructions

D4A4048XA

vers. 2.0

CE

EN



© 2021 SILCA S.p.A - Vittorio Veneto

This manual has been drawn up by SILCA S.p.A.

All rights reserved. No part of this publication may be reproduced or used in any form or by any means (photocopying, microfilm or other) without the written permission of SILCA S.p.A.

Edition: March 2021

Printed in India

by MINDA SILCA Engineering Ltd.

Plot no.37, Toy City, GREATER NOIDA (U.P.) - 201308

The Manufacturer declines any responsibility for possible inaccuracies in this document due to printing or transcription errors.

The Manufacturer reserves the right to alter the information without prior notice, except when they affect safety. This document or any of its parts cannot be copied, altered or reproduced without written authorization from the Manufacturer. Keep the manual and look after it for the entire life cycle of the machine.

The information has been drawn up by the manufacturer in his own language (Italian) to provide users with the necessary indications to use the key-cutting machine independently, economically and safely.

IMPORTANT NOTE: in compliance with current regulations relating to industrial property, we hereby state that the trade-marks or trade names mentioned in our documentation are the exclusive property of authorized manufacturers of locks and users.

Said trade-marks or trade names are nominated only for the purposes of information so that any lock for which our keys are made can be rapidly identified.

IMPORTANT

ATTENTION:



- 1) Following the norms of air transport safety, the battery provided in the machine is in discharged condition. The battery connection of the machine is also disengaged from PCB. This point is also applicable to Shipping by Sea.
- 2) Please engage the battery connection and make sure to charge the machine up to 100% before use.

INSTRUCTIONS:

- A) Carefully turn the key-cutting machine onto its back as shown in below picture.
- B) To open the Electric Cover, Open screws (R1), (R2) & (R3) as shown below.

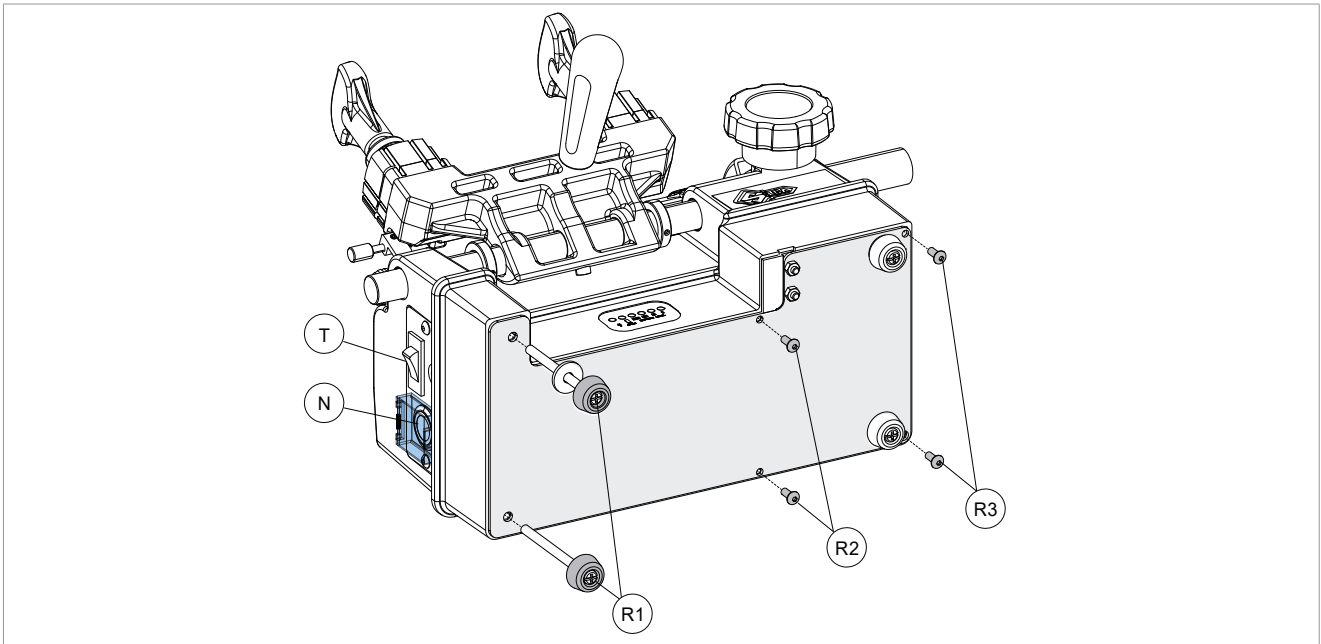

- C) Make sure that both switches (T) and (N) are turned off.
- D) Connect the Battery Wire to the PCB in the Battery Terminal as shown below

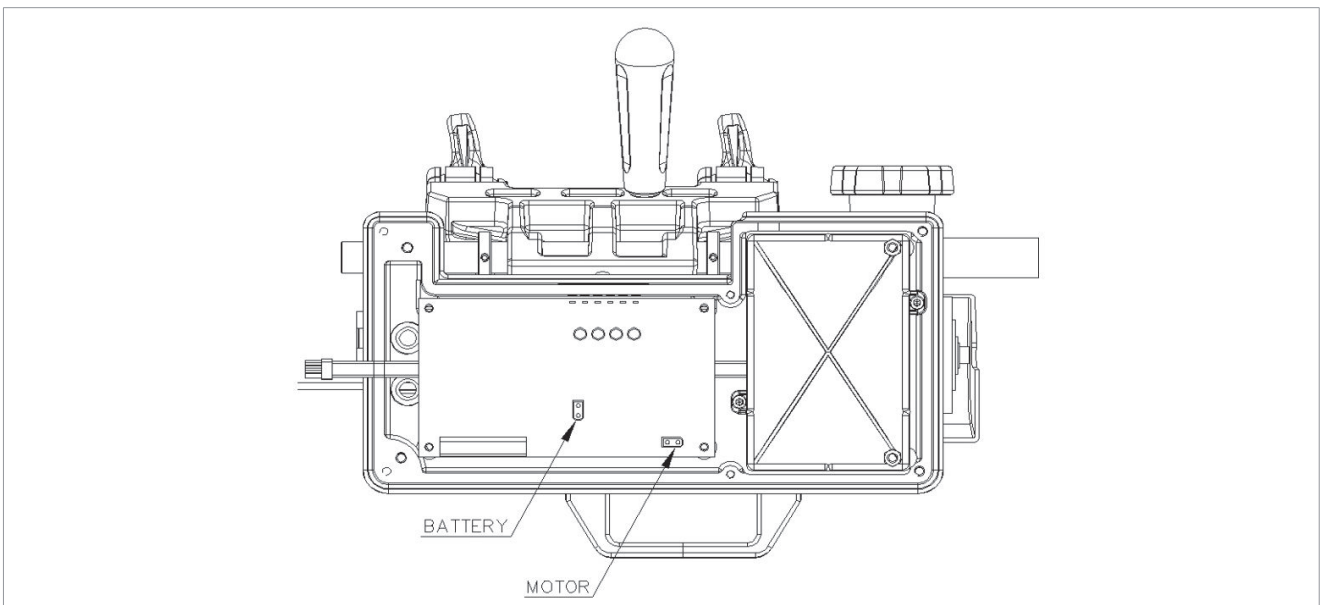

- E) Tight the Electric Cover and return the machine to its upright position on the work top. Before use, please charge the machine with its adapter till the LED shows 100% Charged.

INDEX

USE OF THE MANUAL	1
GENERAL WARNINGS	3
1 MACHINE DESCRIPTION	4
1.1 Main working parts	6
1.2 Technical Data	7
1.3 Battery	8
1.4 Electric circuit	9
1.5 Accessories provided	10
2 TRANSPORT	11
2.1 Packing	11
2.2 Unpacking	11
2.3 Handling the machine	11
3 MACHINE INSTALLATION AND PREPARATION	12
3.1 Checking for damage	12
3.2 Environmental conditions	12
3.3 Positioning	12
3.4 Separate parts	12
3.4.1 Carriage handle	12
3.4.2 Fixing bracket	13
3.5 Connection to external sources	14
4 MACHINE REGULATION AND UTILIZATION	15
4.1 Checking and calibration	15
4.2 Calibration	15
5 CUTTING OPERATIONS	18
5.1 Key cutting	18
5.1.1 Clamp rotation	19
5.1.2 Securing the keys in the clamps	19
5.1.3 Key cutting	20
5.2 Using the accessories	20
6 MAINTENANCE	22
6.1 Replacing the brush	22
6.2 Replacing the cutting tool	23
6.3 Replacing the tracer point	23
6.4 Depth regulation (clamp protection)	24
6.5 Access to the lower compartment	24
6.6 Battery Replacement Instructions	25
6.7 Replacing the main switch	26
6.8 Replacing the motor start switch	27
6.9 Replacing and/or adjusting tension on the belt	28
7 DISPOSAL	29
8 ASSISTANCE	30
8.1 How to request service	30

USE OF THE MANUAL

This manual has been drawn up by the Manufacturer and is an integral part of the machine literature. The manual gives information that is obligatory for the operator to know and which makes it possible to use the machine safely.

User's Manual

This user's manual is provided because it is essential for proper use and maintenance of the machine. The manual must be kept carefully throughout the life of the machine, including the decommissioning stage. Keep in a dry place close to the machine where it is always at hand for the operator.



ATTENTION: IT IS OBLIGATORY to read the manual carefully before using the machine.

Readers' characteristics

This manual must be read and its contents acquired by those who will use the machine.

Manufacturer's ID

FLASH MOBILE has an ID plate located on the right side of the machine, showing the serial number.

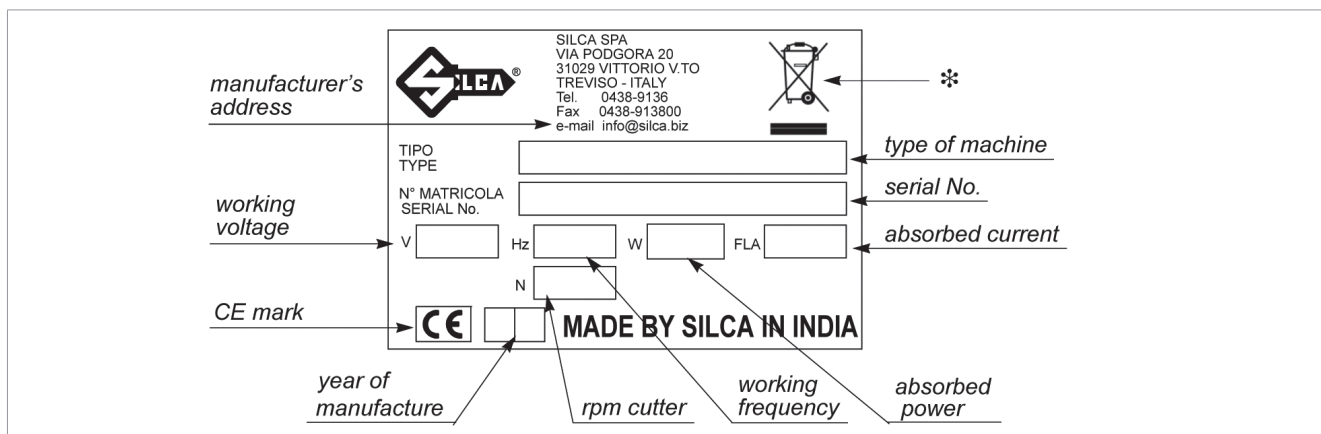

Fig. 1

(*) see chap. 7 DISPOSAL.

How to apply for after-sales service

Silca provides purchasers of the FLASH MOBILE with After-Sales Service. For the total safety of the operator and machine, any service not described in the manual must be carried out by the manufacturer or in the special Service Centres recommended by Silca.

At the end of the manual there is a list of manufacturers' and authorized Service Centre addresses; if the manual was downloaded is necessary visit the website to see the contacts (www.silca.biz).

The warranty card attached to the machine covers free repairs or replacement of faulty parts for 24 months from the date of purchase**.

All service must be agreed by to by the user with Silca or the Service Centre.

(**) Damage caused by negligence or wrong use of the machine by the user will null the warranty.

Battery and Charging Adapter life are 500 nos. charging cycle or 6 months which ever is earlier.

TERMINOLOGY

For those inexperienced in the subject of keys and key cutting, below is an illustration of the most frequently used terms:

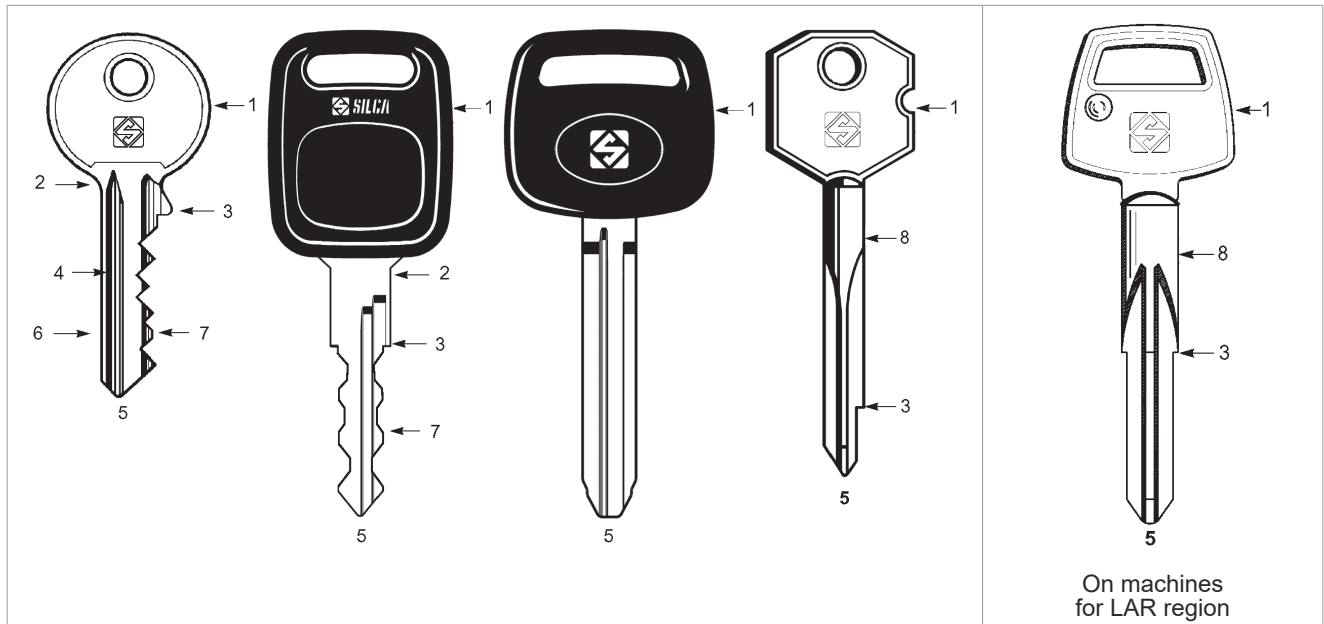

Fig. 2

1) Head	3) Stop	5) Tip	7) Cuts
2) Neck	4) Blade	6) Back	8) Stem

GRAPHICS IN THE USER'S MANUAL

Pay attention	Obligation to read the manual

GRAPHICS ON THE FLASH MOBILE MACHINE

Obligatory use of safety goggles	Read instructions before use	WARNING! cutting tool in motion	WARNING! Crushing hazard	CAUTION BEWARE OF MOVING MACHINERY WARNING! Entanglement hazard

GENERAL WARNINGS

FLASH MOBILE is designed to the principles of European Standards (CE). Right from the design stage solutions have been adopted to eliminate hazards for the operator in all the stages of use: handling, regulation, use and maintenance.

The materials used in manufacture and the components employed in using FLASH MOBILE are not dangerous and ensure that the machine complies with current standards.

Silca S.p.A. has also experimented and applied numerous technical solutions that allow the key-cutting machine to optimize the quality of the cut keys.

To guarantee maintaining these results over time, please follow the instructions below:

- **Observe the procedures described in this manual;**
- **Always use Original Silca Tools as they are designed to make the best of FLASH MOBILE and provide quality key-cutting;**
- **Use Silca key blanks, made with top quality materials;**
- **Have the key-cutting machine checked periodically by an authorized Silca After-Sales Service Centre;**
- **Use only original battery and battery charger.**
- **Do not try to disassemble Battery, or give pressure on it, expose to heat or fire as it may EXPLODE.**
- **Do not run the motor while charging.**
- **Always use Silca Original Spare Parts. Beware of imitations!**

NORMAL USE

FLASH MOBILE key-cutting machine must be installed and used according to the rules and specifications established by the manufacturer.

The key-cutting machine must be used only by skilled personnel (professional use).

The FLASH MOBILE key-cutting machine is designed for use on business or industrial premises (e.g. hardware shops, key cutting centers, etc...).

Any other use different from that indicated in this manual will cause the forfeiture of all customers' rights to make claims on Silca S.p.A. and may be an unknown source of hazard for the operator or third parties.



ATTENTION: negligent use or failure by the operator to observe the instructions in this manual are not covered by the warranty and the manufacturer declines any responsibility in such cases.

SAFETY

The key-cutting machine is built entirely to standards. The operations for which it has been designed are easily carried out at no risk to the operator.

The adoption of general safety precautions (wearing protective goggles) and observation of the instructions provided by the manufacturer in this manual eliminate all human error, unless deliberate.

The key-cutting machine is designed with features which make it completely safe in all its parts.

RESIDUAL RISKS

There are no further risks arising from the use of the machine.

SAFETY REGULATIONS

- **Always provide to turn off the machine when not in service and before carrying out any kind of maintenance work.**
- **Always work with dry hands free of grease or oil.**
- **Never pull the battery charger cord too hard and ensure that it does not come into contact with oil, sharp objects or heat source.**
- **Do not use the machine in dangerous environments (wet or damp).**
- **All visitors, especially children, must stay at a safe distance from the machine and must never come into contact with the electric wiring. This equipment should not be used where children may be present.**
- **Remove the battery wire connection from PCB before leaving the machine unused for a long period of time.**

1 MACHINE DESCRIPTION

FLASH MOBILE is a professional cutting machine for duplicating flat keys used with cylinder, car locks and cruciform keys.

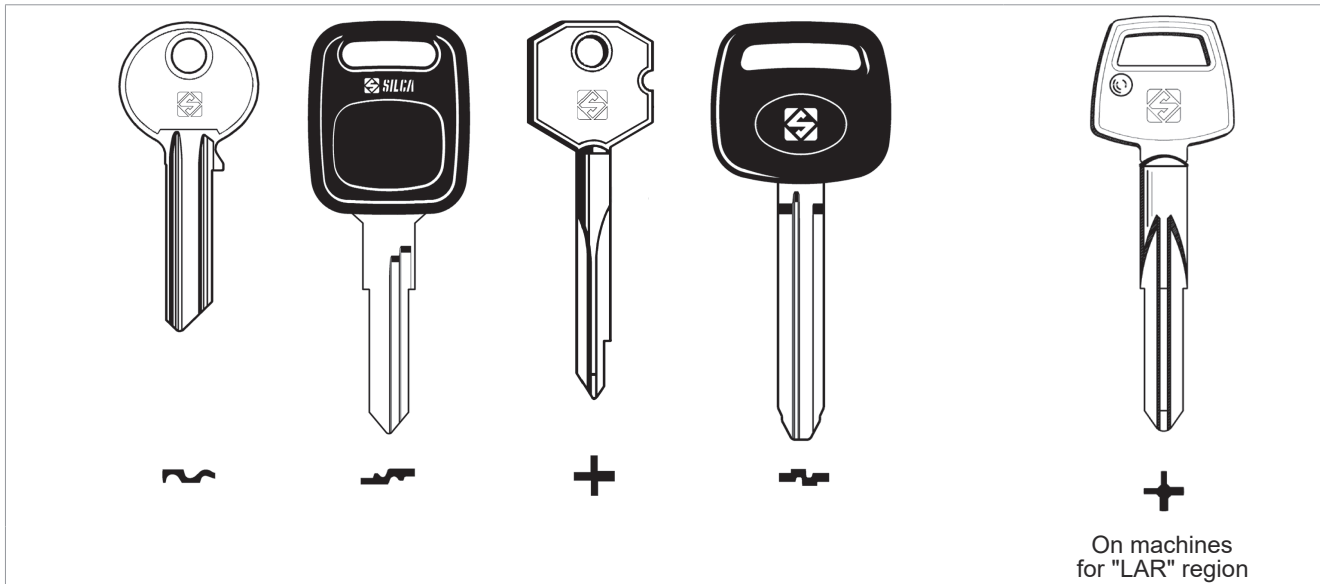

Fig. 3

The main parts of the machine are described below:

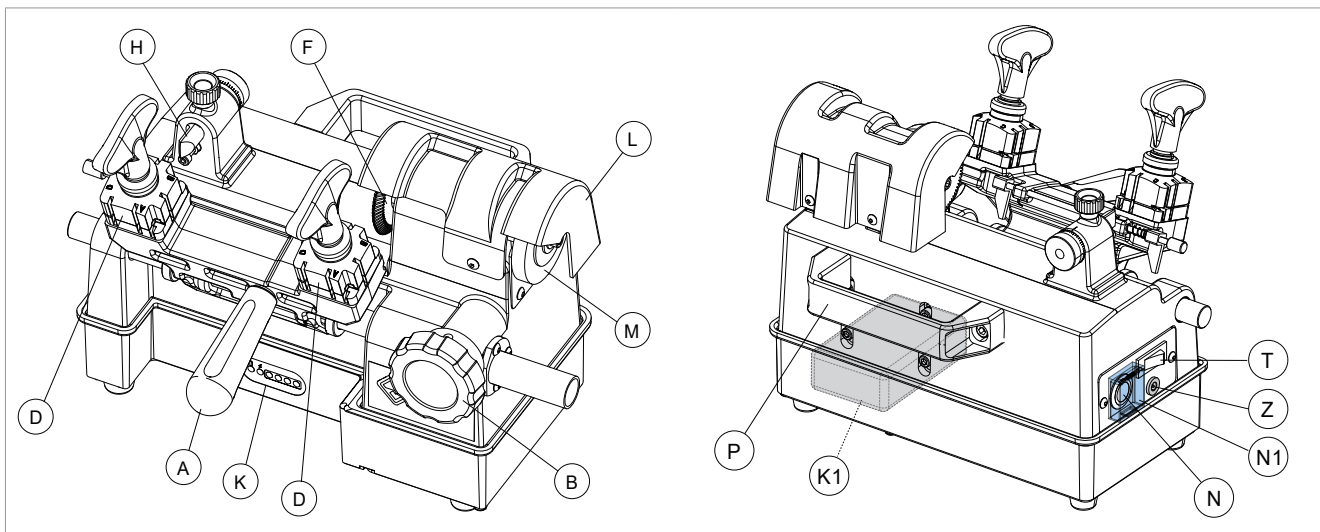

Fig. 4

- **Battery power supply**

The machine is powered by a lithium-ion battery (K1) located inside the machine body. To recharge the battery, use the charging device supplied with the machine.

The charge level is shown on the display (K) located on front of the machine.

With fully charged battery, you can cut:

- about 200 steel keys;
- about 300 brass keys.

- **Main power switch**

The machine is turned on by means of the switch (N) located on its left-hand side. It is located inside a switch protection (N1) to prevent from becoming switched on inadvertently. Switch protection (N1) should be lifted to switch ON the switch (N) and closed when the machine is not in use.

- **Motor start switch**

The switch (T) starts the motor.

- **Motor and transmission unit**

Motor transmission takes place by belt. On the right-hand side of the motor there is the transmission shaft which moves the cutting tool (F) and the brush (M). These components are protected by the protective cover (L).

- **Clamp carriages**

Carriage (C) is moved horizontally by means of knob (B). The carriage holds 2 clamps (D) and has a handle (A) for front movement.

- **Cutting unit**

The cutting unit contains the actual working parts of the FLASH MOBILE key-cutting machine, which operate together to cut and finish keys "read" from the originals. The working parts are described below:

Cutting Tool

The cutting tool (F) is the part of the FLASH MOBILE used for cutting key blanks. The cutting tool is in HSS super rapid steel and is protected by a special cover (L) to ensure safe operation.

Tracer point

The tracer point (H), dedicated to reading the cuts on keys to be copied is housed on the left-hand side of the machine. Depth is easily regulated by means of the relevant centesimal ring nut (G).

Clamps

The clamps (D) are rotating and four-sided to allow perfect closure of the key placed on its back or profile in the case of keys with symmetrical cuts (cap.5.1).

Clamp knobs

The clamps are locked by two ergonomic knobs (E), which ensure perfect grip on the keys with only slightly locking force.

Gauges

Next to the clamps there is a rod with two gauge tabs to control key alignment for shoulder gauged keys.

Brush

The purpose of the brush (M) is to deburr the keys after cutting. It is made of accident proof material and is protected by a shield (L).

1.1 Main working parts

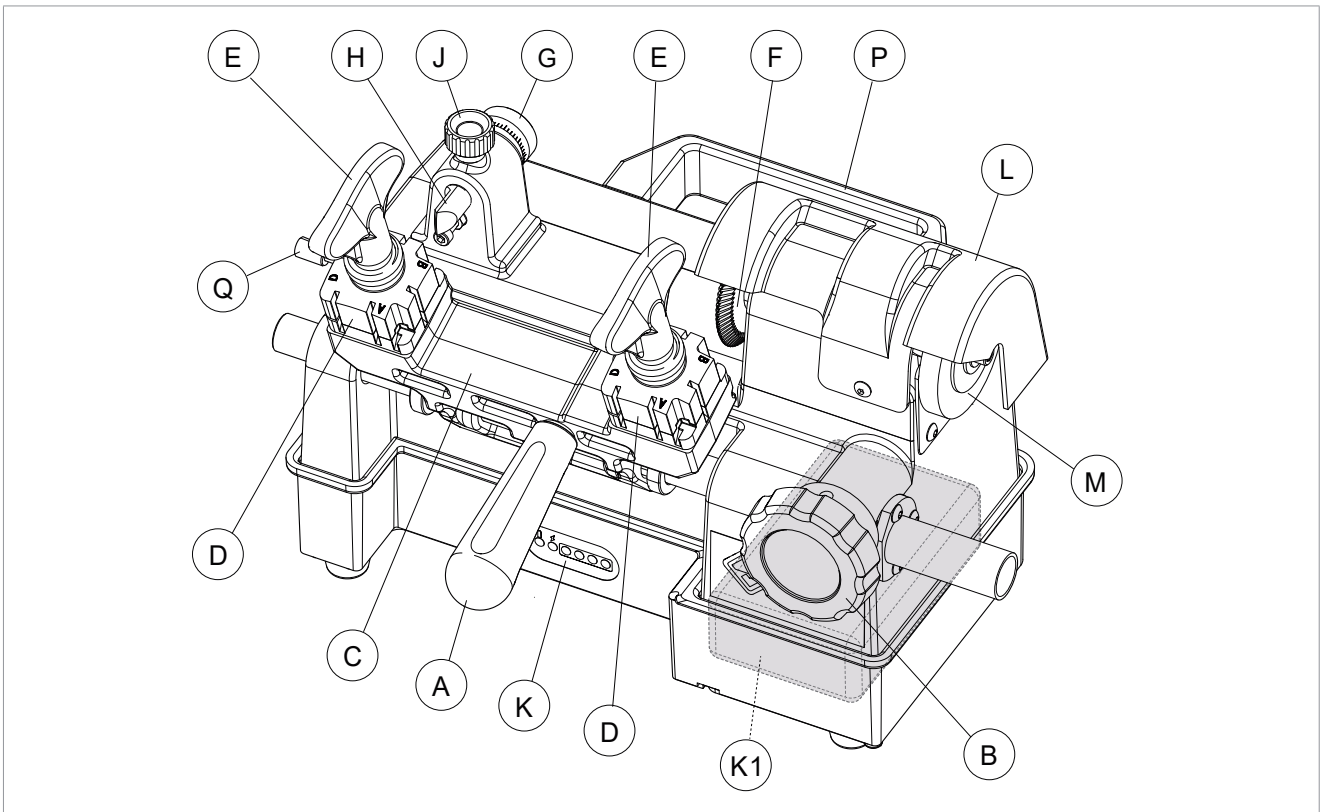

Fig. 5

- A - carriage handle
- B - carriage movement knob
- C - clamp carriage
- D - clamps
- E - clamp knobs
- F - cutting tool
- G - tracer point ring nut
- H - tracer point
- J - tracer point locking knob
- K - charge viewer display
- K1 - battery
- L - cutter/brush cover
- M - brush
- N - main power switch
- N1 - main power switch protection
- P - handle for machine transport
- Q - gauges knob
- T - motor start switch
- Z - socket for battery charger

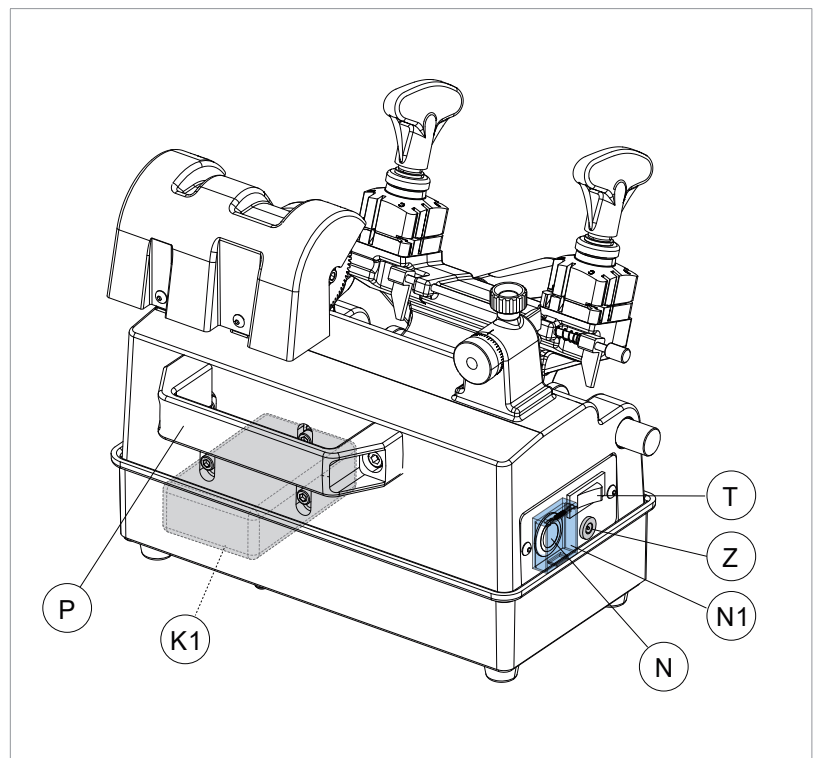

Fig. 6

1.2 Technical Data

Power supply:	Li-Ion Battery 22,2V 2900 mAh Power adaptor: MeanWell GST60A24-P1J - 24V - 2.5A
Cutter motor:	12VDC 120W - 500 hours of life cycle
Movements:	by rectified carriage shaft and rack
Cutting tool:	HSS Super Rapid Steel - coated
Tool speed:	2200 rpm +/-10%
Runs (maximum length of cuts):	42 mm
Dimensions:	width: 320 mm - depth: 250 mm - height: 250 mm
Mass:	Kg. 8.7
Noise level:	sound pressure Lp(A) = - for Brass key: 78 dB(A) - for Steel key: 80 dB(A)

1.3 Battery

On the front side, the machine bears a LED display showing the battery charge level.

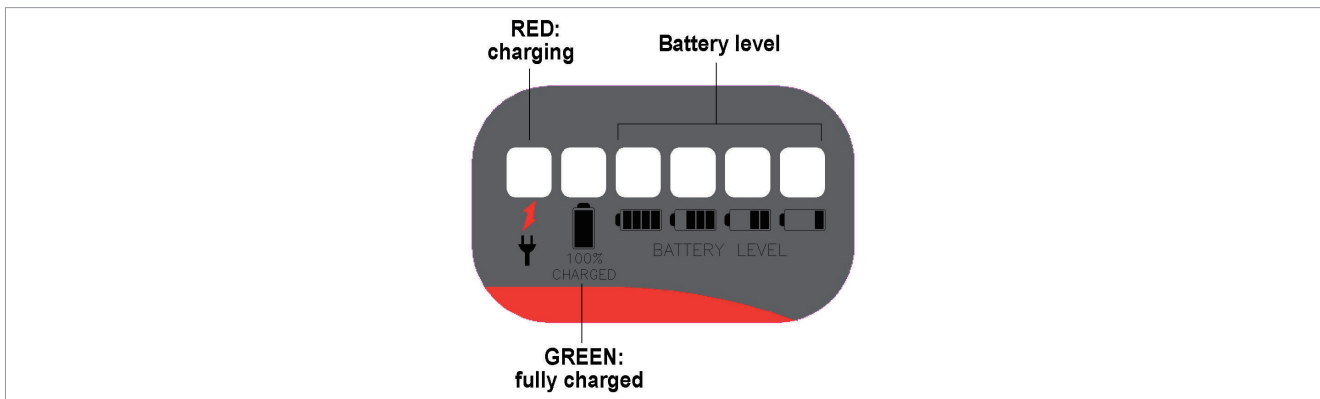

Fig. 7

	<p>On full charge, it will turn GREEN. Remaining same.</p>	<p>GREEN: the battery has been fully charged. Unplug the power cord. With fully charged battery, the key cutting machine can encrypt from 200 to 300 keys.</p>
	<p>During charging, this LED will turn RED. On reaching full charge, this LED will turn OFF. Charging may take 3 - 4 hours.</p>	<p>RED: charging.</p>
	<p>Led Indicators</p>	<p>The 4 led show the charge level</p>

WARNINGS FOR CHARGING THE BATTERY

- Use original battery charger and cord.
- Use a grounded power outlet.
- It is recommended not to perform any maintenance operation during charging.

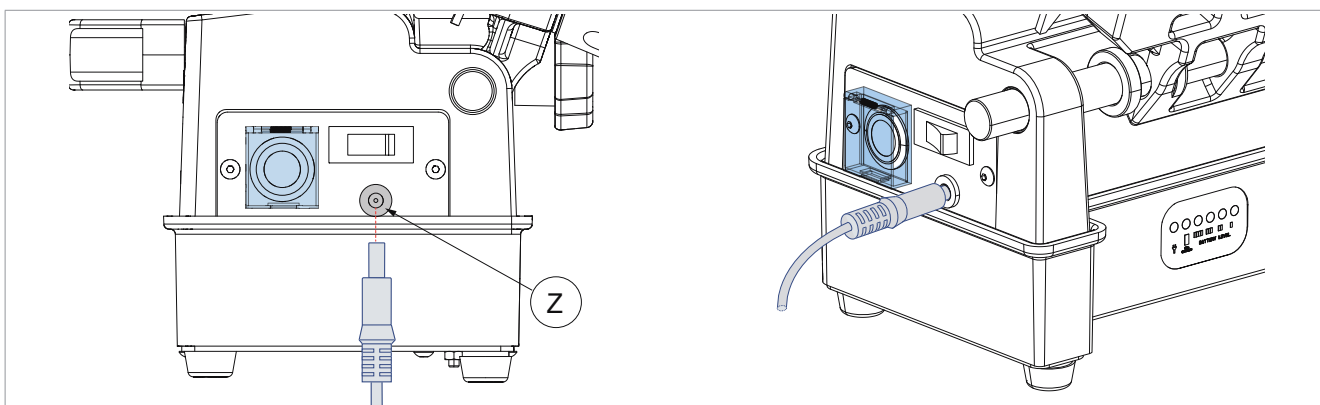

Fig. 8

1.4 Electric circuit

The main parts of the electric circuit on the key-cutting machine are listed below:

- 1) Power adaptor
- 2) Socket for battery charger
- 3) Main switch
- 4) Card
- 5) 22.2V battery
- 6) 12V-DC motor
- 7) Motor switch 24V DC 16A

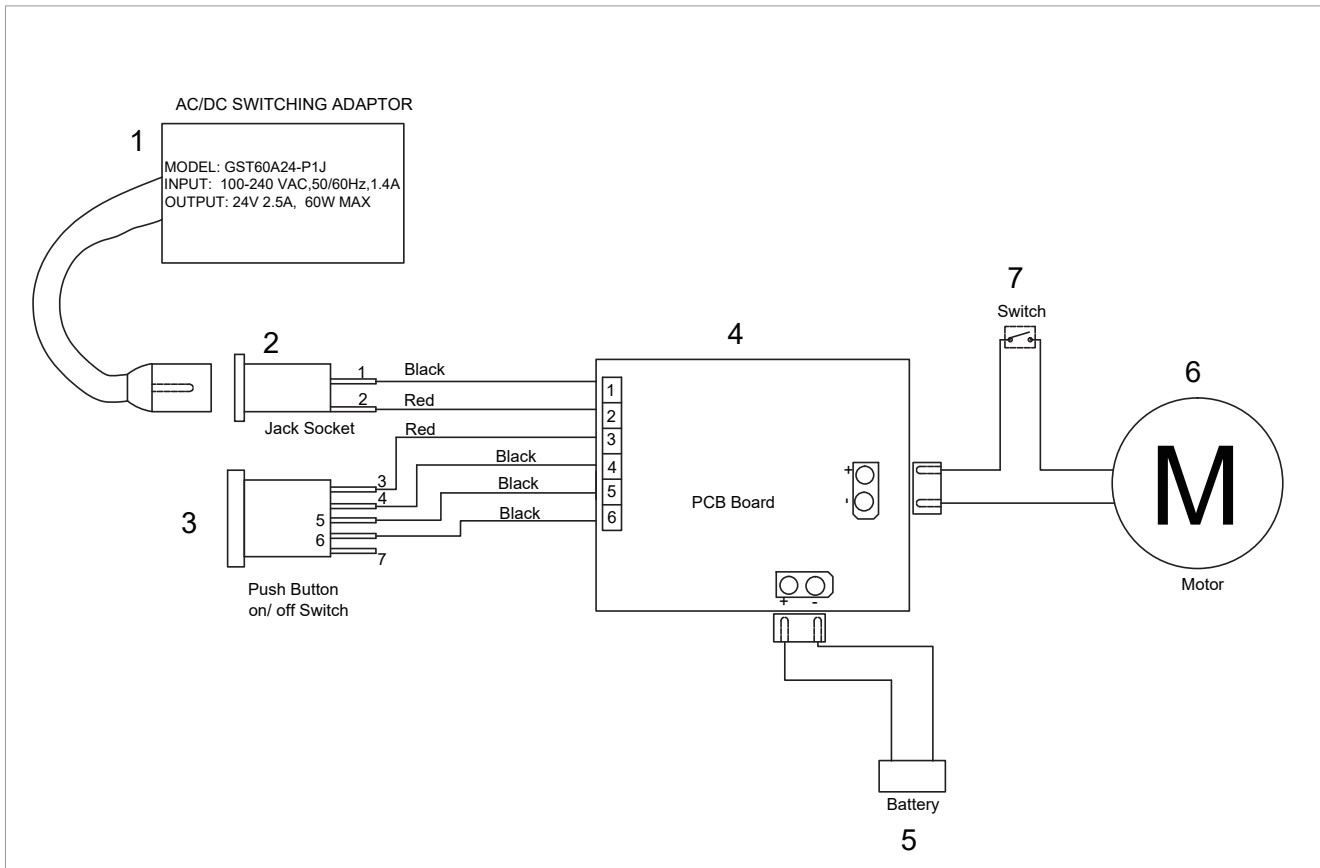

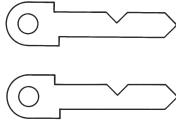

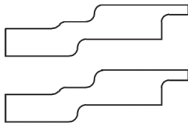

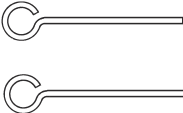

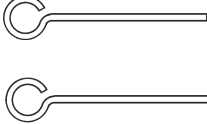



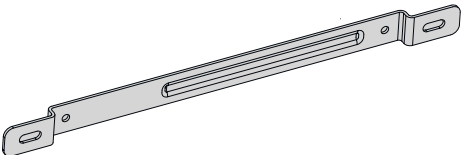

Fig. 9

1.5 Accessories provided

FLASH MOBILE comes with a set of accessories for its operation and maintenance (tools, hex wrenches, fuses) supplied in a special tool kit comprising:

<p>allen key 2,5 mm</p> 	<p>adjusting keys (2 pcs)</p> 
<p>allen key 3 mm</p> 	<p>steel bars (2 pcs)</p> 
<p>allen key 4 mm</p> 	<p>steel pin Ø 1,20 mm</p> 
<p>cutter release rod</p> 	<p>steel pin Ø 1,70 mm</p> 
<p>universal adapter (for "LAR" region)</p> 	<p>stubby screwdriver</p> 

Separately:

<p>fixing bracket</p> 	<p>battery charger device</p> 
---	--

2 TRANSPORT

FLASH MOBILE key-cutting machine is easily transported and is not dangerous to handle. The packed machine can be carried by one person.

2.1 Packing

The FLASH MOBILE is packed in a strong cardboard box, the dimensions of which are shown in Fig. 10 sufficiently robust to be used for storing the machine for long periods.

Inside the box the machine is enclosed in expanded polymer shells. The shells and cardboard box ensure safe transportation and protect the machine and all its parts.

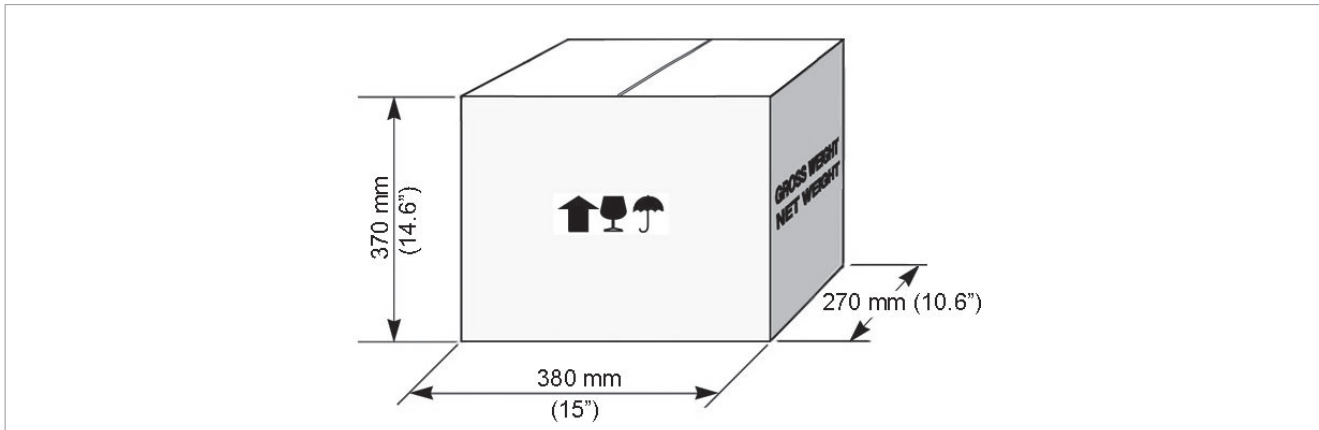

Fig. 10



Keep dry



Handle with care



This side up

NOTE: to avoid damaging the key-cutting machine it must always be transported in its packing case. This will prevent sudden movements or rough handling from damaging the machine, persons or things.

2.2 Unpacking

To remove the machine from the packing box:

- 1) Cut the straps with scissors and remove,
- 2) Open the box without damaging it as it may be used again (e.g. removals, dispatch to the manufacturers for repairs or servicing),
- 3) Check the contents of the box, which should comprise:
 - 1 FLASH MOBILE key-cutting machine packed in a protective shell;
 - 1 set of documents, including: operating manual, spare parts list and warranty;
 - 1 carriage handle;
 - 1 battery charging device;
 - 1 tool set;
 - 1 fixing bracket;
- 4) Remove the key-cutting machine from the protective shell.

2.3 Handling the machine

When the FLASH MOBILE has been unpacked, place it directly on its workbench. This operation can be carried out by one person.



ATTENTION: firmly hold the handle (P) for machine transport, and no other part, to lift and carry the machine.

3 MACHINE INSTALLATION AND PREPARATION

The key-cutting machine can be installed by the purchaser and does not require any special skills. However, some checks and preparation for use need to be carried out by the operator.

3.1 Checking for damage

FLASH MOBILE key-cutting machine is solid and compact and will not normally damage if transport, unpacking and installation have all been carried out according to the instructions in this manual.

However, it is always advisable to check that the machine has not suffered any damage.

3.2 Environmental conditions

To ensure that the best use is made of the key-cutting machine, certain parameters must be borne in mind: damp, badly ventilated sites should be avoided.

The ideal conditions for the machine are:

- temperature: between 10°C and 40°C; relative humidity: 60% ; room illumination: approximately 500 Lux.

3.3 Positioning

- 1) Place the key-cutting machine on a horizontal surface, solid enough to take the weight (8,7 Kg).

- to work with ease, we suggest that the workbench be approximately the height of the operator's hip.
- it is important to leave clearance of at least 30cm (12") behind the machine and on each side to ensure proper ventilation (Fig. 11).

- 2) Make sure machine voltage is suitable for the mains supply and that the latter is earthed with a differential switch.

- 3) Read instruction "IMPORTANT" initial page of the manual carefully and connect the power lead (power pack) to the machine (chap.3.5).

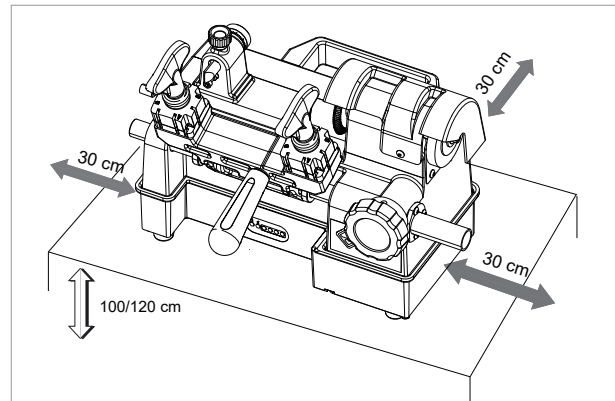

Fig. 11

3.4 Separate parts

The separately packed parts must be installed on the FLASH MOBILE key-cutting machine by the purchaser, as follows:

3.4.1 Carriage handle

Screw the handle (A) onto the carriage (A) (Fig. 12).

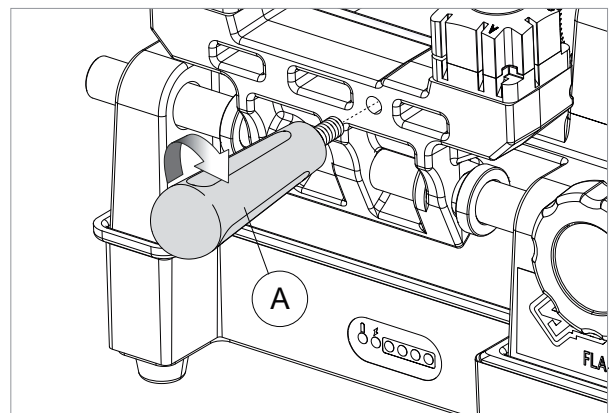

Fig. 12

3.4.2 Fixing bracket

The machine can be fixed to the workbench with a special bracket (provided).
Proceed as follows:

⚠ ATTENTION: turn off the machine with motor switch (T), turn off main power switch (N), close the switch protection cover (N1) and check that it is NOT connected to the battery.

- 1) Paying attention turn the machine slowly onto its back.
- 2) To remove the Bottom Plate, loosen and remove the front screws (R1), (R2) and (R3) (Fig. 13).
- 3) Loosen screw (R4) from the bottom plate (Fig. 13).
- 4) Remove the washers (R5) (Fig. 14) from the front foot and fix the Fixing Bracket it its place (Fig. 15).
- 5) Return the machine to its upright position and fix it on the work top (Fig. 16).

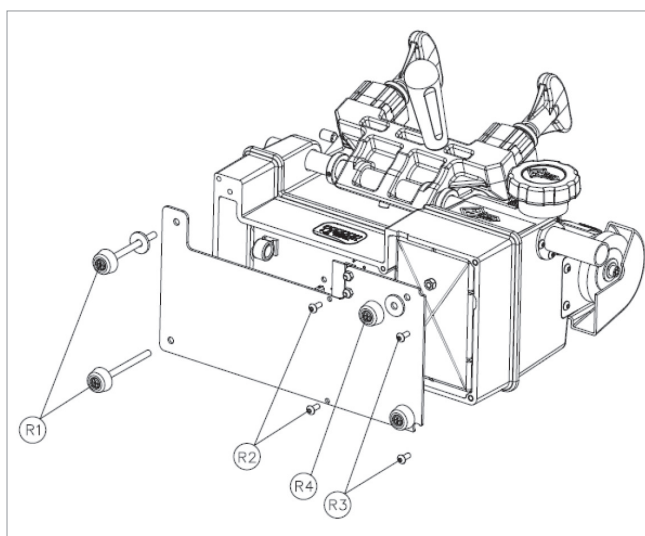

Fig. 13

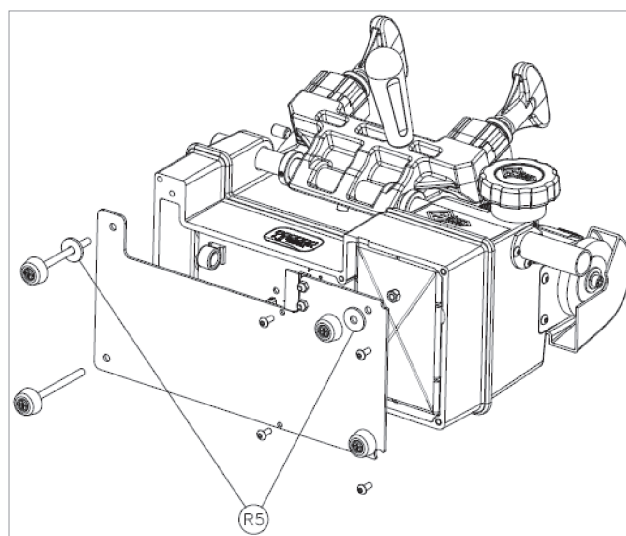

Fig. 14

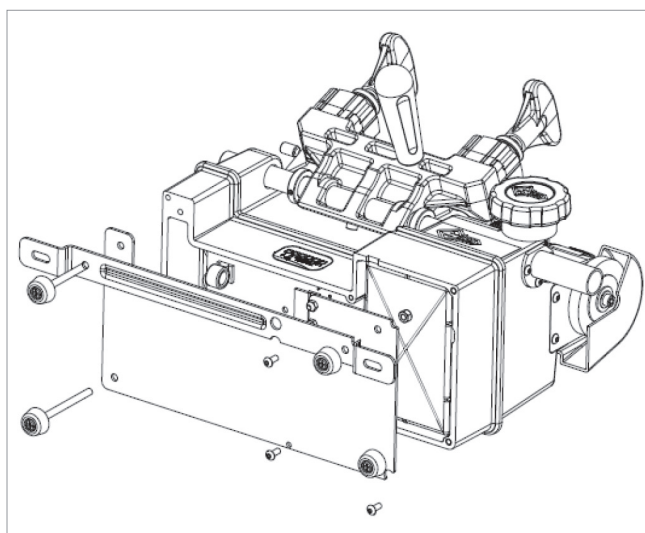

Fig. 15

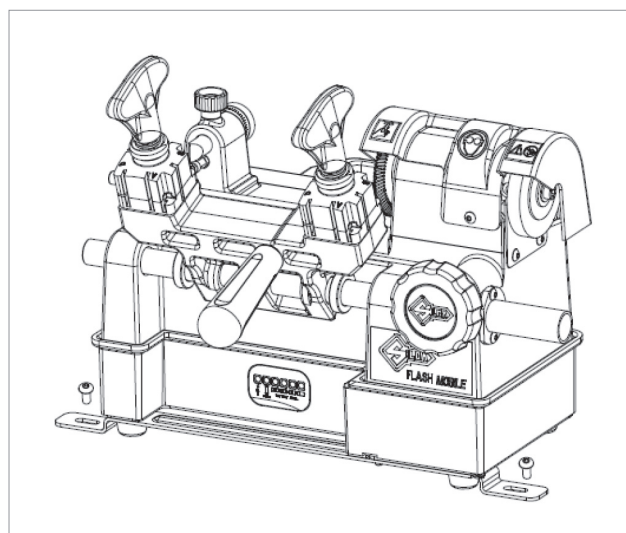

Fig. 16

3.5 Connection to external sources

Before, please ensure Battery terminal should be connected. Do not use the machine during charging as it may cause over heating of battery and may damage critical component.

To charge the battery, it is necessary to connect the charger to the socket (Z) of the machine and to the power source.

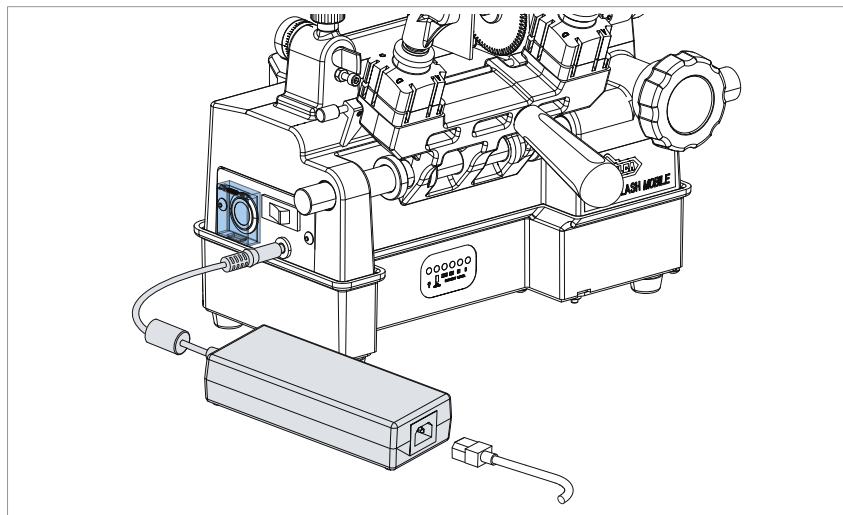

Fig. 17

4 MACHINE REGULATION AND UTILIZATION

4.1 Checking and calibration

The cutting tool on the machine is the part used to cut the key blanks and should be periodically checked and replaced, if necessary.

Every time the cutting tool is changed, and during periodical operational tests, check calibration.

4.2 Calibration

The FLASH MOBILE key-cutting machine requires two types of calibration: **axis** and **depth**.

Axis calibration:

Axis calibration is regulation of the space between cutting and the stop (Fig. 18 and Fig. 19).

The axis setting for the FLASH MOBILE is fixed and is established on assembly in our workshops.

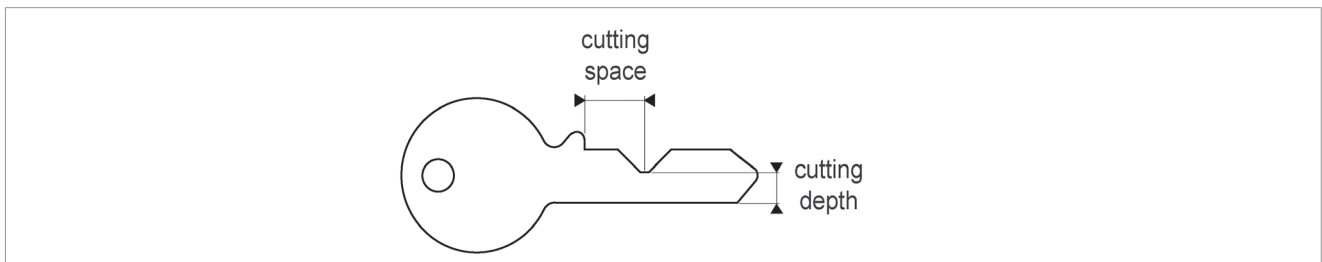

Fig. 18

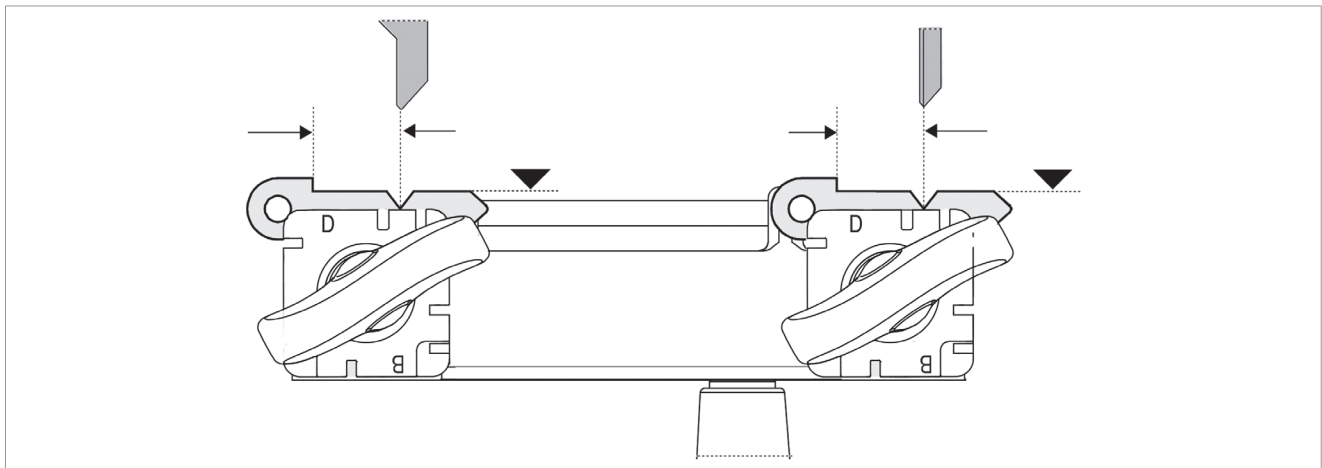

Fig. 19

Depth calibration:

Depth calibration is regulation of the cutting depth (Fig. 18). Proceed as follows:

- 1) Turn off the machine with motor switch (T), turn off main power switch (N), close the switch protection cover (N1) and check that it IS NOT connected to the battery.
- 2) Place the adjustment keys (provided) on the clamps (Fig. 20).
- 3) Check that the adjustment plates adhere properly to the clamps.
- 4) Turn the shoulder gauge rod towards the operator so that the gauges (Q1) are in contact with the adjusting plates (Fig. 20).
- 5) Lower the gauge rod.

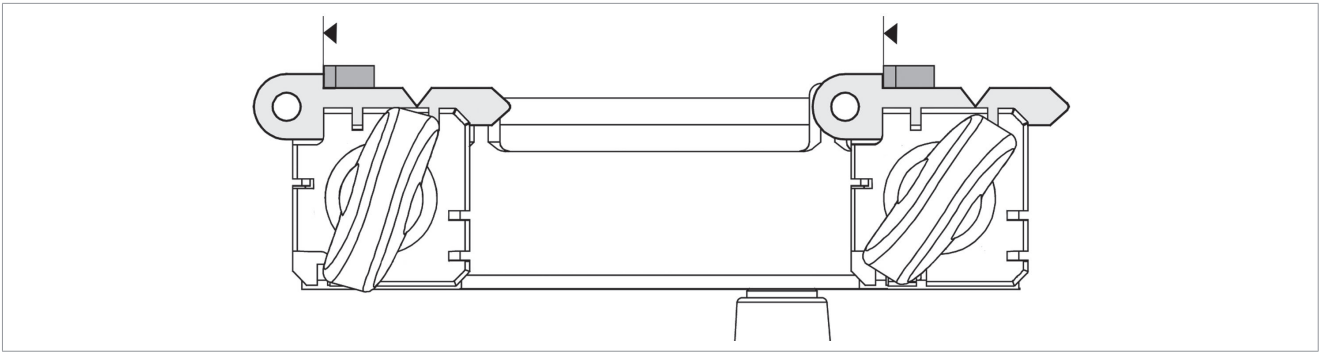

Fig. 20

- 6) Raise the carriage up to the cutting tool.
- 7) Move the keys into contact with the cutting tool and tracer point (Fig. 21).
- 8) Turn the cutting tool counterclockwise manually and check that it skims the adjusting keys in several places.
- 9) If necessary, regulate the depth of the cut with the micrometric tracer point, as follows:
 - a) loosen the tracer point locking knob (J).
 - b) turn the ring nut (G) clockwise to advance the tracer point (shallower cuts) (Fig. 22).
 - c) turn the ring nut (G) counterclockwise to return (deeper cuts) (Fig. 23).

NOTE: each notch on the centesimal ring corresponds to 0,025 mm (.00098") (Fig. 21).

- 10) Repeat these operations until regulation is complete, then tighten the tracer point locking knob.

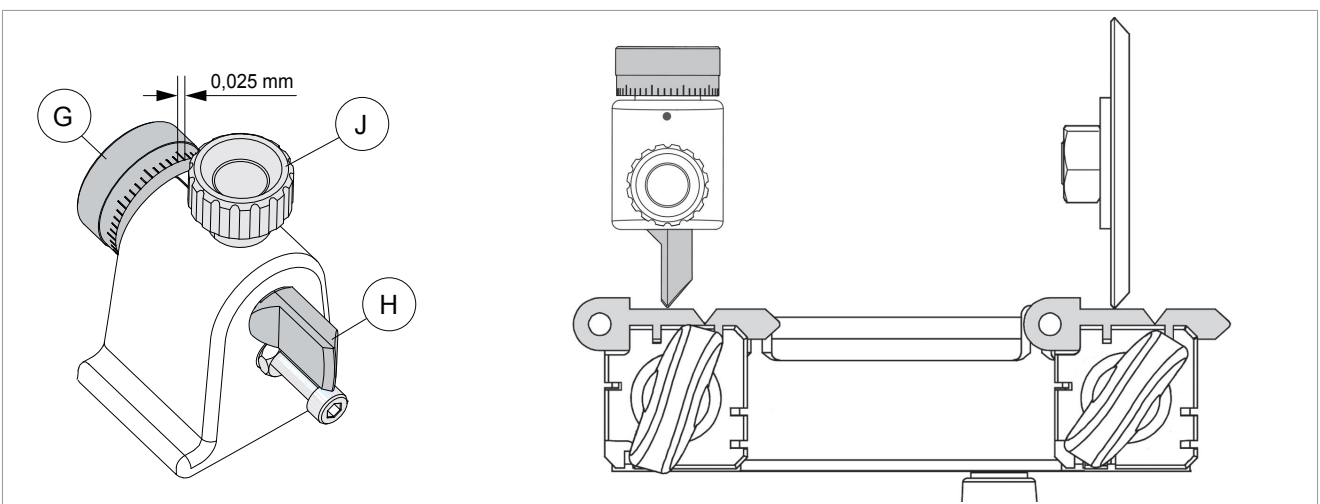

Fig. 21

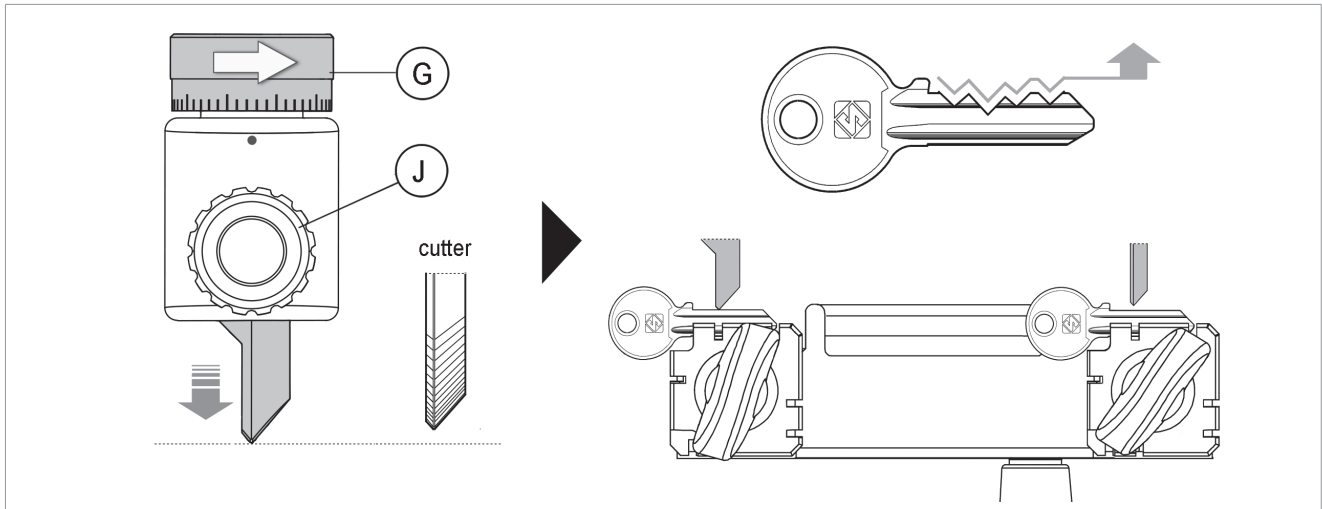

Fig. 22

- Turn the nut to the RIGHT (clockwise) to move the tracer point out. Result: SHALLOWER CUTS.

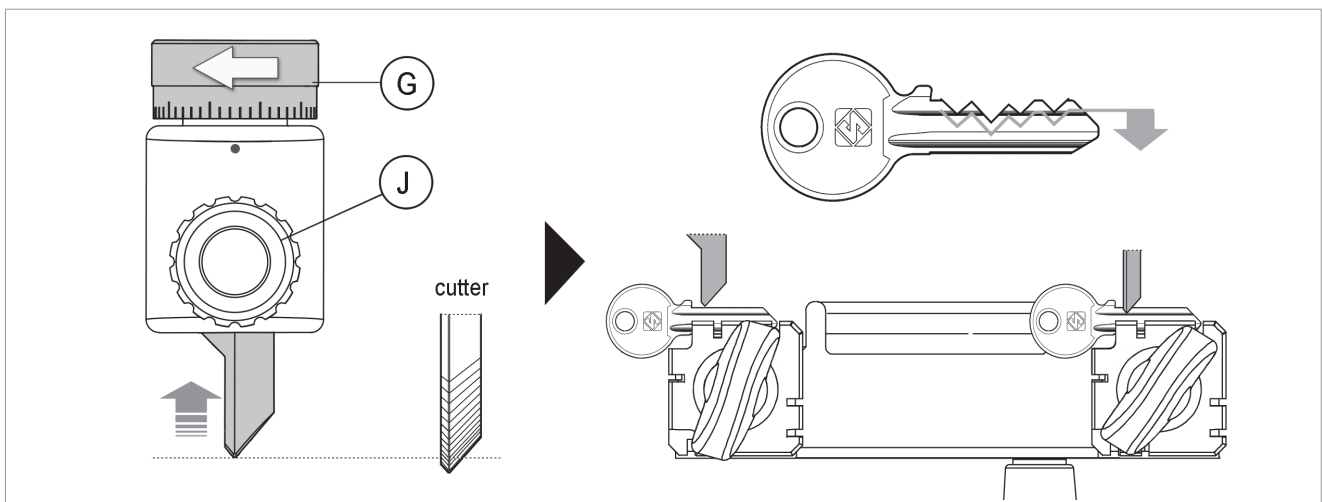

Fig. 23

- Turn the nut to the LEFT (counterclockwise) to return the tracer point. Result: DEEPER CUTS.

5 CUTTING OPERATIONS



ATTENTION: for complete safety during the cutting operations, take the following precautions:

- Always work with dry hands.
- Wear protective goggles even if the machine has a protective shield over the cutting tool.
- Turn on motor switch (T) only after completing the operations on the carriage (securing the keys...).
- Keep hands away from the cutting tool in motion.
- Before duplicating, remove the gauges.

5.1 Key cutting

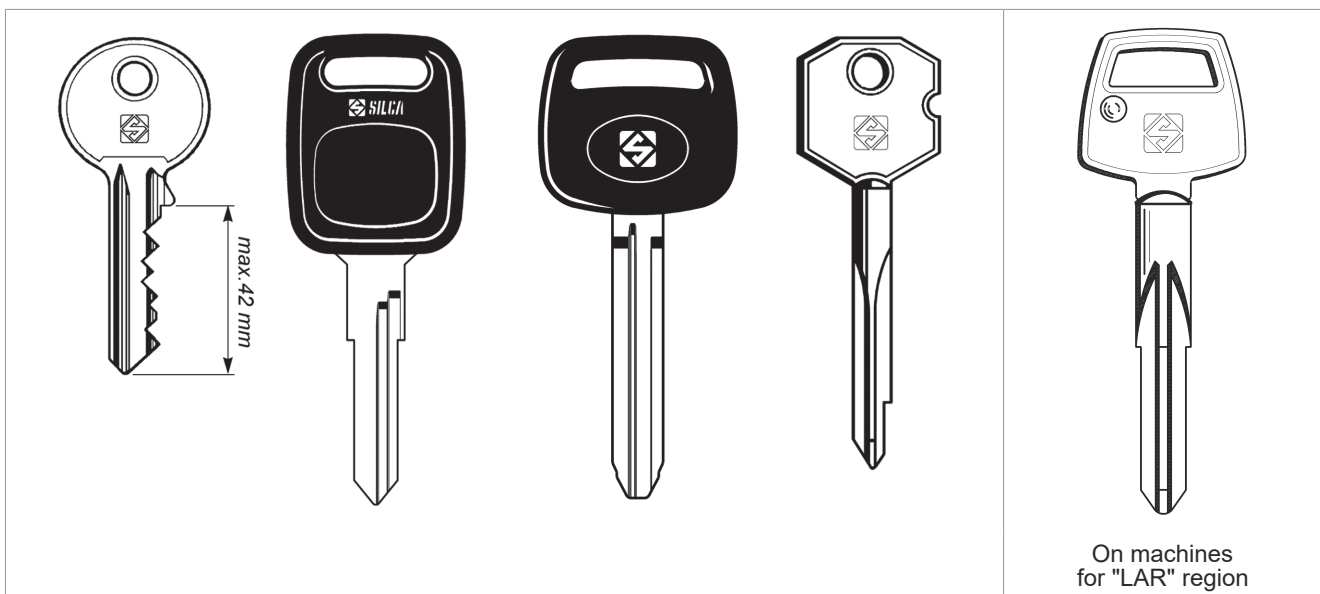

Fig. 24

Place the clamps on the required side (see chap.5.1.1):

- **Side A** of the clamp: for keys to be fitted on their backs, keys with double cuts without groove and cruciform keys (Fig. 25);
- **Side B** of the clamp: for keys placed on their backs and having cuts with a depth of less than 3,9 mm (Fig. 25);
- **Side C and D** of the clamp: for keys to be cut on both sides and locked on the groove (Fig. 25).

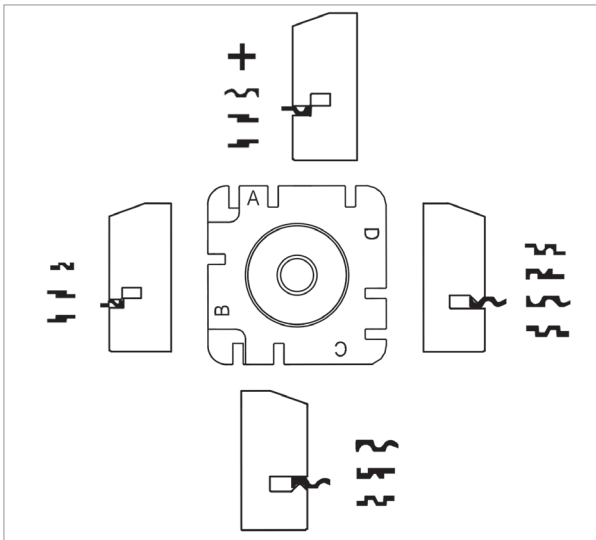

Fig. 25

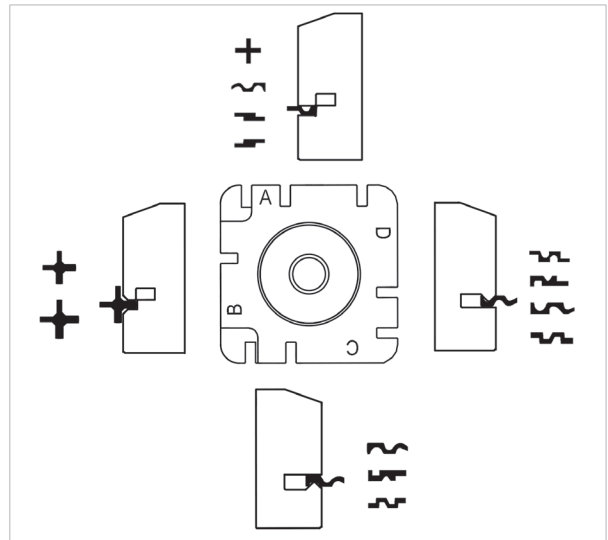

Fig. 26 - for "LAR" region

5.1.1 Clamp rotation

- 1) Loosen the clamp closing knob by a few turns.
- 2) Turn the clamp so that the required side is facing the tracer point and cutter.

NOTE: carry out the operation for both clamps.

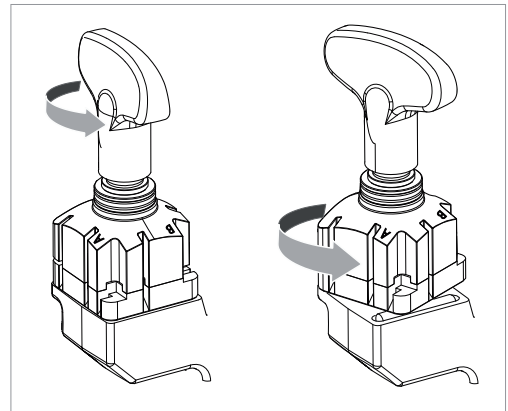

Fig. 27

5.1.2 Securing the keys in the clamps

- 1) Position the original key (left-hand jaw) and key blank (right-hand jaw), ensuring that:
 - a) the keys are well positioned and secured in the clamp;
 - b) the key stop is resting against the calibration tab (Q1);
- 2) Secure the keys by closing the clamps with knobs (E).
- 3) Lower the gauge rod by turning knob (Q).

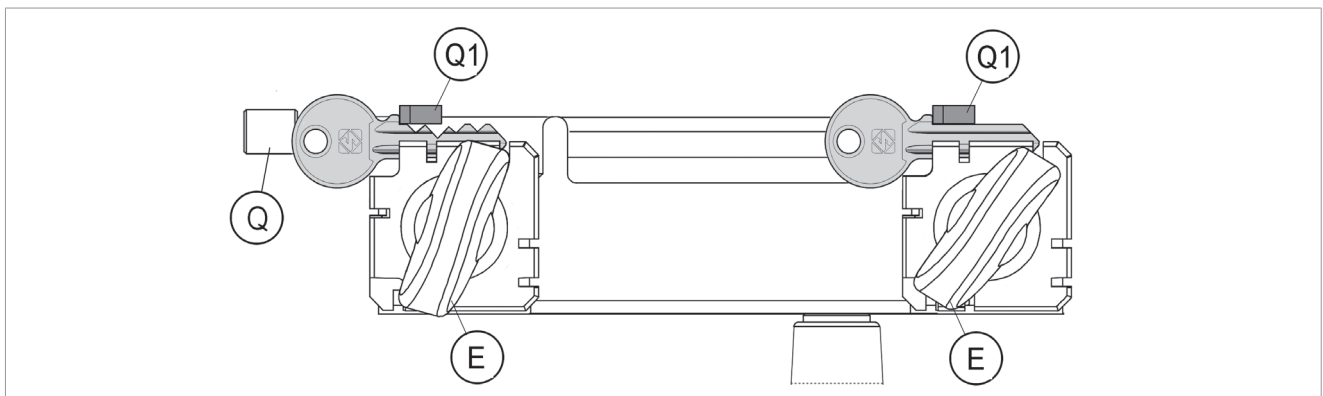

Fig. 28

5.1.3 Key cutting

! **ATTENTION:** make sure the gauges (Q1) have been lowered.

When the key-cutting machine has been turned on by means of main switch (N) it is ready for cutting:

- 1) Use handle (A) to take the carriage towards the tracer/cutter and hold the tracer against the cut, starting at the key stop (Fig. 29).
- 2) To make a copy of the key, move the carriage from right to left with knob (B). In case of double cuts repeat the operation in the second side of the key.
- 3) **Turn off the machine with motor switch (T), turn off main power switch (N), close the switch protection cover (N1) and check that it is NOT connected to the battery.**
- 4) Remove the keys from the clamps.
- 5) Turn on the machine with switch (N) and smooth off the key edges by means of the brush (M).

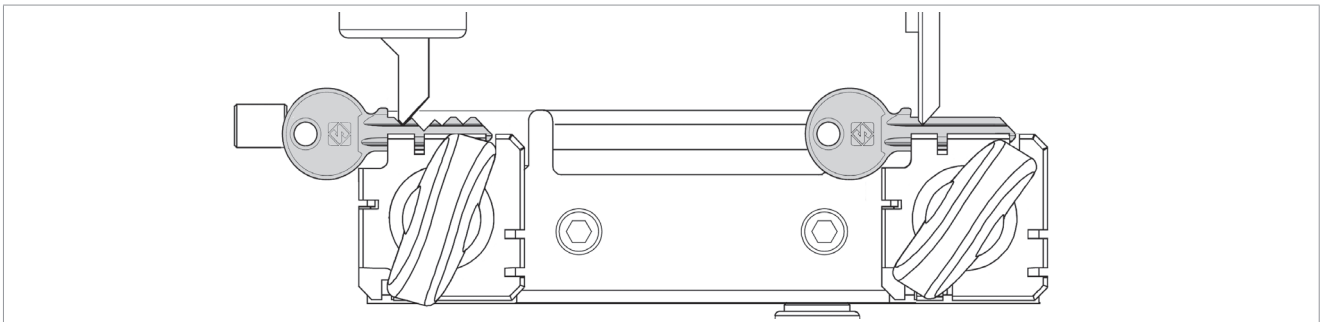

Fig. 29

5.2 Using the accessories

The accessories provided with machine to assist key-cutting are:

- pins
- bars

Using the pins

The pins must be inserted between the bottom of the jaw and the back of the key for keys with narrow stems, and their purpose is to ensure that the key protrudes sufficiently to be cut properly (Fig. 30-B, Fig. 30-C).

For keys with narrow, thin stems, two pins must be used (Fig. 30-B) the second one to give a secure grip on the key. If the key thickness is too fine to guarantee a good grip in the clamps, a pin must be used (Fig. 30-A).

! **ATTENTION:** the pins provided have two different diameters: 1,20 mm and 1,70 mm; It is essential to use pins with the same diameters for locking both the original and the key blank.

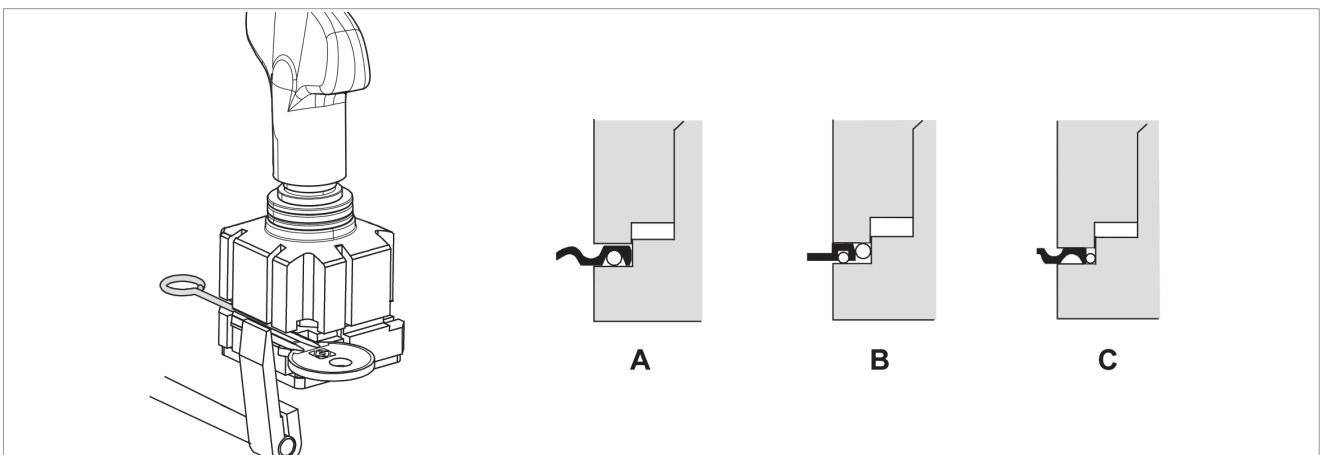

Fig. 30

Using the bars

The bars provided are used for cutting cruciform keys (Fig. 31) and as a tip rest for gauging keys without shoulders (Fig. 32).

Cutting cruciform keys using bars

The cruciform keys (90°) can be cut with the clamps and the aid of the bars.

Positioning cruciform keys:

- 1) Leave the gauges (Q1) in the idle position.
- 2) Insert the bars into the slot in the clamps.
- 3) Butt the key stop against the bars.
- 4) Secure the keys in the clamps.
- 5) Remove the bars from the clamp grooves to prevent it being touched by the tracer point or cutting tool.
- 6) Cut the first side.
- 7) Repeat the operation, turning both keys in the same direction for the other positions.

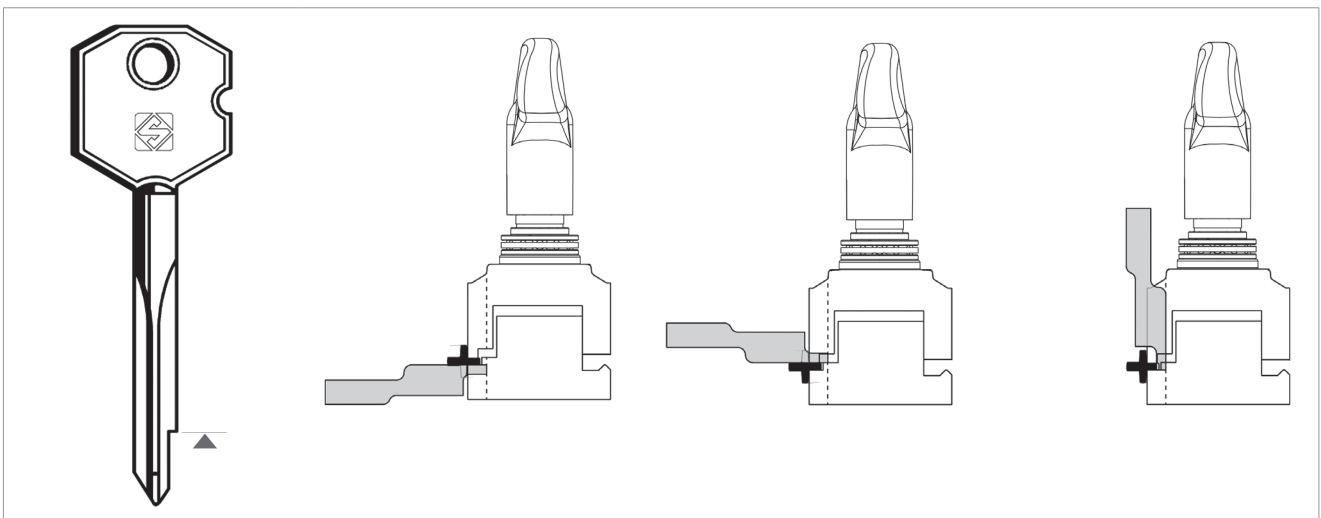

Fig. 31

Tip stop with a bar

The bars can be used with keys without shoulders (Fig. 32). Proceed as follows:

- 1) Leave the gauges (Q1) in the idle position.
- 2) Insert the bars into the slot in the clamps.
- 3) Rest the tip of the key against the bar.
- 4) Secure the key and remove the bar.

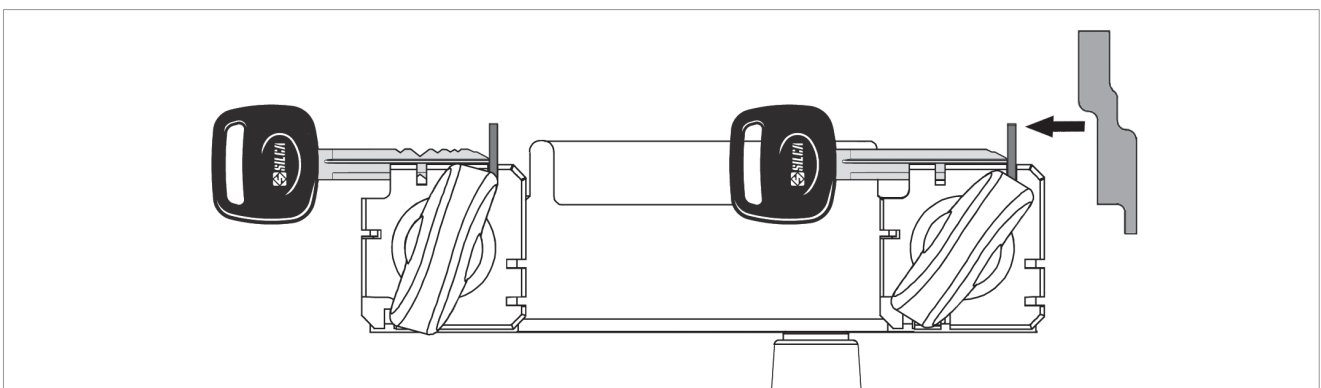

Fig. 32

6 MAINTENANCE

⚠ ATTENTION: for repairs or replacement of parts for maintenance, the 'CE' mark is guaranteed only if original spare parts provided by the manufacturer are used.

Although the key-cutting machine does not require special maintenance, it is advisable to check and, if necessary, replace the parts subject to wear, such as: the belt, cutting tool, brush, tracer point. Replacement is simple and can be carried out by the operator.

CLEANING: Keep the carriage and clamps free of chippings from the cutting operations by cleaning with a dry brush.

⚠ ATTENTION: DO NOT USE COMPRESSED AIR!

⚠ ATTENTION: to keep the machine well maintained we recommend using protective oil, e.g. WD40 or similar, applied to the burnished mechanical parts. This prevents oxidation of the parts in question (clamps, guides, carriages...).

Before starting any type of maintenance (checks or replacements), read the instructions below:

- CHECK THAT THE MACHINE IS SWITCHED OFF AND THE SWITCH PROTECTION (N1) COVER IS CLOSED.
- Check that the machine IS NOT connected to the battery charger.
- Follow all the instructions in the manual to the letter.
- Use original spare parts.
- Always check that any screws or nuts removed when replacing a piece are properly tightened.

6.1 Replacing the brush

When the brush no longer cleans off the burrs it must be replaced as follows:

⚠ ATTENTION: turn off the machine with motor switch (T), turn off main power switch (N), close the switch protection cover (N1) and check that it is NOT connected to the battery.

- 1) Remove the cover (L) by loosening the 3 screws (L1) (Fig. 33).
- 2) Slot the locking rod (provided) into the hole (K) of the cutting tool shaft (Fig. 34).
- 3) Use the Allen wrench to loosen the screw (M1) holding the brush (M) in place (Fig. 34).
- 4) Replace the brush and tighten the screw (M1) with the Allen key.
- 5) Remove the locking rod from the cutting tool shaft.
- 6) Install the protective cover (L) and secure with the 3 screws (L1).

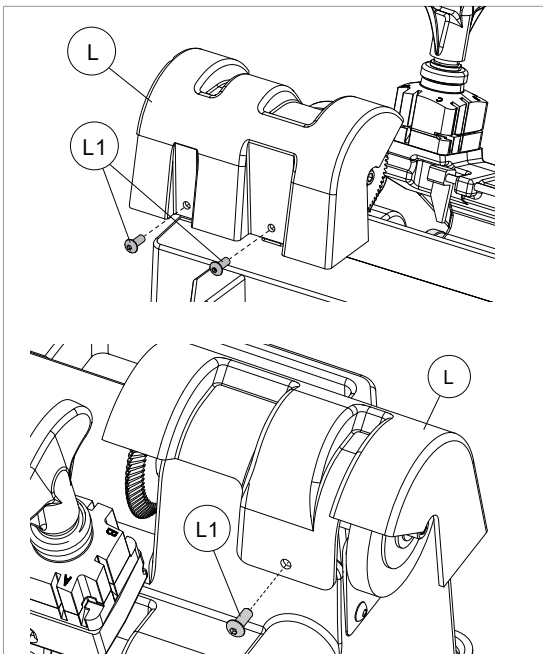

Fig. 33

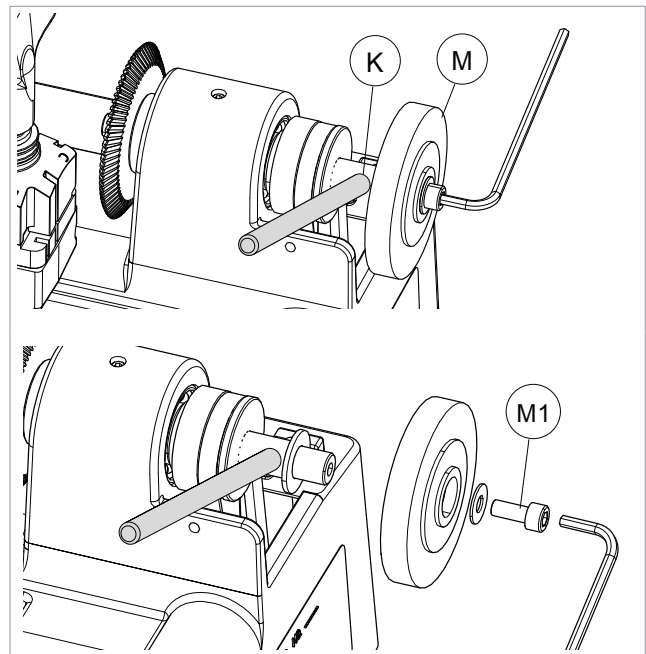

Fig. 34

6.2 Replacing the cutting tool

In order to substitute the cutting tool you need to remove the cutting tool protective cover (L). To replace a worn cutting tool, proceed as follows:

⚠ ATTENTION: turn off the machine with motor switch (T), turn off main power switch (N), close the switch protection cover (N1) and check that it is NOT connected to the battery.

- 1) Remove the cover (L) by loosening the 3 screws (L1) (Fig. 33).
- 2) Slot the locking rod (provided) into the hole (K) of the cutting tool shaft (Fig. 35).
- 3) Unscrew (clockwise) the cutting tool locking screw (F1).

⚠ ATTENTION: the thread is left-handed.

- 1) Remove the worn cutting tool.
- 2) Carefully clean the new cutting tool and its seat.
- 3) Install the new cutting tool (pay attention to the rotation direction), place the washer and tighten screw (F1) anticlockwise.
- 4) Remove the locking rod.
- 5) Re-place the protective cover (L).
- 6) Check calibration (see chap.4.2).

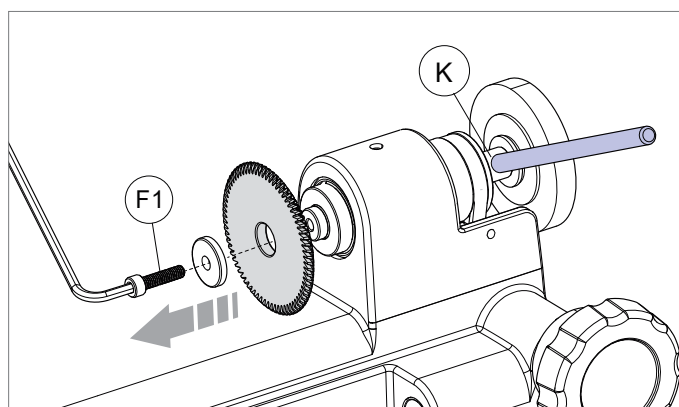

Fig. 35

6.3 Replacing the tracer point

⚠ ATTENTION: turn off the machine with motor switch (T), turn off main power switch (N), close the switch protection cover (N1) and check that it is NOT connected to the battery.

- 1) Loosen the knob (J) (Fig. 36).
- 2) Loosen the ring nut (G) completely and remove the tracer. Attention: the spring may stay in place.
- 3) Fit a new tracer and tighten the ring nut (G).
- 4) Check calibration (see chap.4.2).

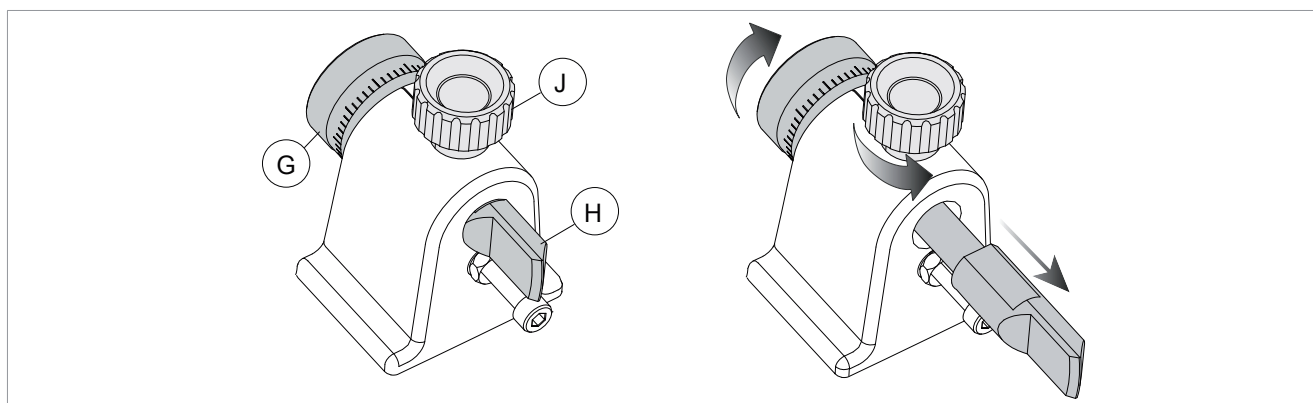

Fig. 36

6.4 Depth regulation (clamp protection)

FLASH MOBILE incorporates regulation to safeguard the clamps from the possibility of scraping against the tracer point and cutter.

⚠ ATTENTION: the play between cutting tool/tracer point and clamps must be 0.2 mm.

Should it be different from this, proceed as follows:

⚠ ATTENTION: turn off the machine with motor switch (T), turn off main power switch (N), close the switch protection cover (N1) and check that it is NOT connected to the battery.

- 1) Raise the carriage and carry the clamps to the end of its run towards tracer point and cutting tool (Fig. 37)
- 2) Release the nut (X1) with the spanner.
- 3) Use the Allen wrench to screw or unscrew the screw (X2) in order to move the carriage away towards or from the tracer point and cutting tool.
- 4) Tighten the nut (X1).

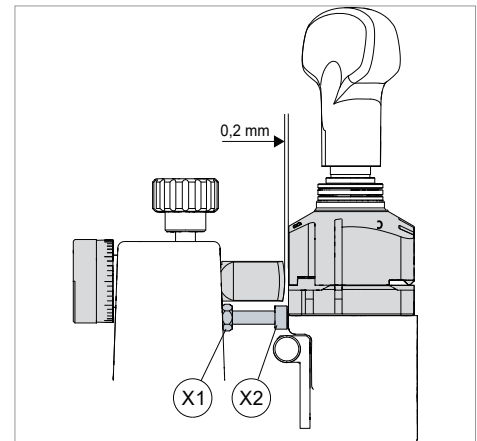

Fig. 37

6.5 Access to the lower compartment

⚠ ATTENTION: turn off the machine with motor switch (T), turn off main power switch (N), close the switch protection cover (N1) and check that it is NOT connected to the battery.

- 1) Carefully turn the key-cutting machine onto its back as shown in picture (Fig. 38).
- 2) Open screws (R1), (R2) & (R3) as shown, then open bottom cover.

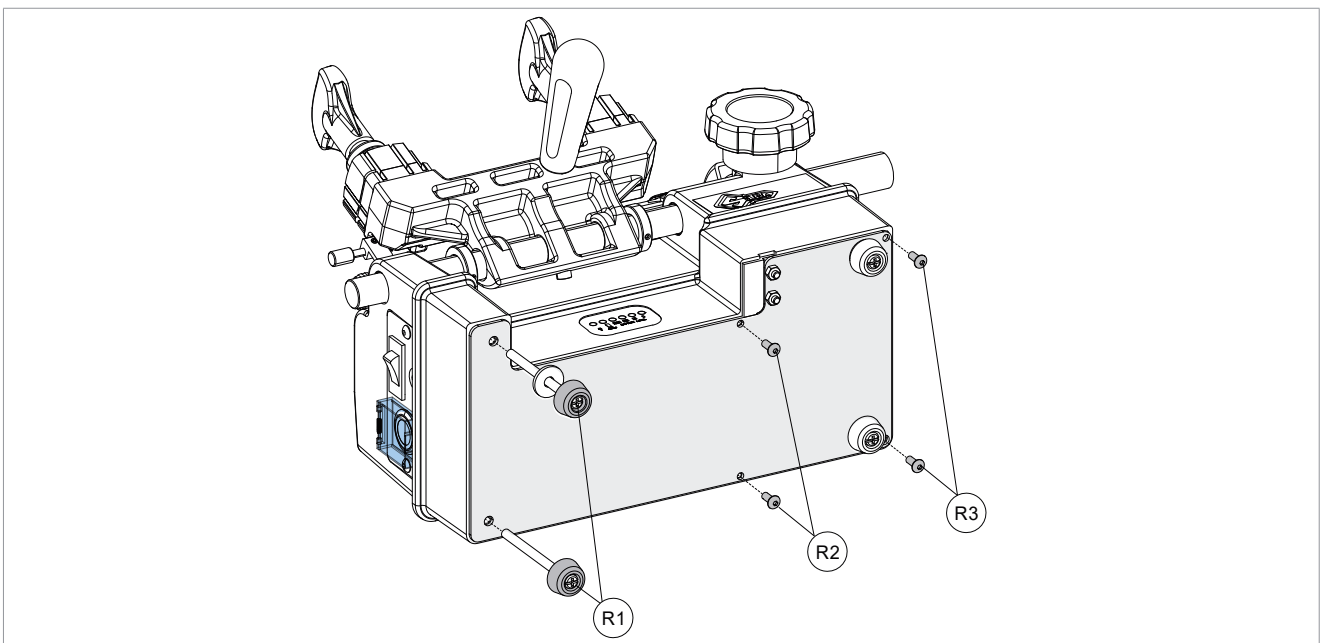

Fig. 38

6.6 Battery Replacement Instructions

⚠ ATTENTION: turn off the machine with motor switch (T), turn off main power switch (N), close the switch protection cover (N1) and check that it is **NOT** connected to the battery.

- 1) Carefully turn the key-cutting machine onto its back as shown in picture (Fig. 39).
- 2) Open screws (R1), (R2) & (R3) as shown, then open bottom cover.
- 3) Disconnect the battery wire from the PCB (see Fig. 40)
- 4) Open screws (B1) & (B2) and pull out the battery (see Fig. 41)
- 5) Put the new battery and tighten the (B1) and (B2) screws.
- 6) Tight the bottom cover and return the machine to its upright position on the work top.

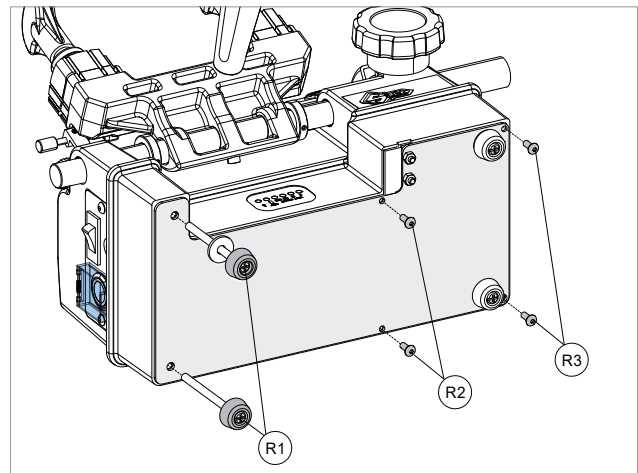

Fig. 39

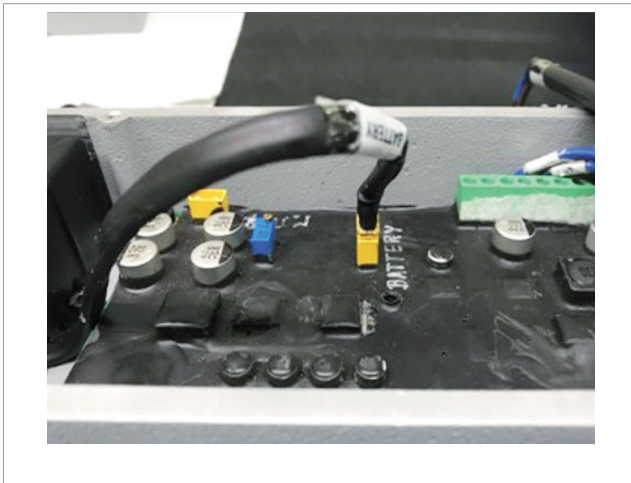

Fig. 40

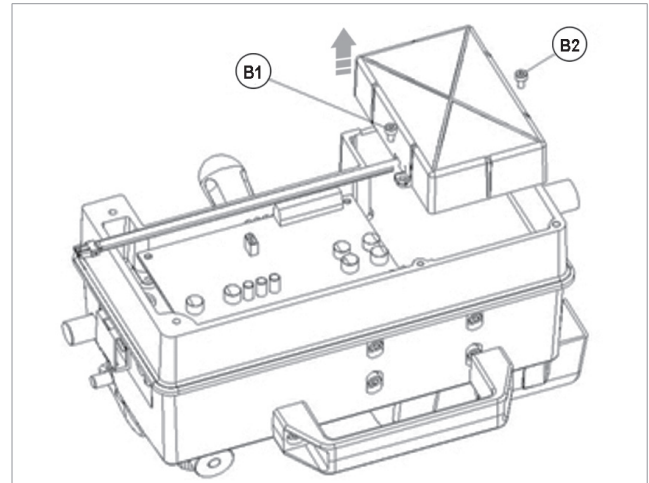

Fig. 41

6.7 Replacing the main switch

⚠ ATTENTION: turn off the machine with motor switch (T), turn off main power switch (N), close the switch protection cover (N1) and check that it is NOT connected to the battery.

- 1) Please refer to chap.6.6 to access the lower compartment and disconnect the battery connection.
- 2) Place the machine in upright position and unscrew (S1) and (S2) screws to open the plate, as shown in Fig. 42.
- 3) To remove cable connections from the main switch (N), carefully open all the four screws (S3) as shown in Fig. 43.
- 4) Unscrew the big nut (S4) and replace the new switch along with switch protection (N1) and secure the big nut (S4).
- 5) To secure back the wiring connections, please follow the Fig. 44 carefully and screw the cables properly.
- 6) Please tight screws (S1) and (S2) to assemble the plate.
- 7) Connect the battery connection and close the lower compartment.

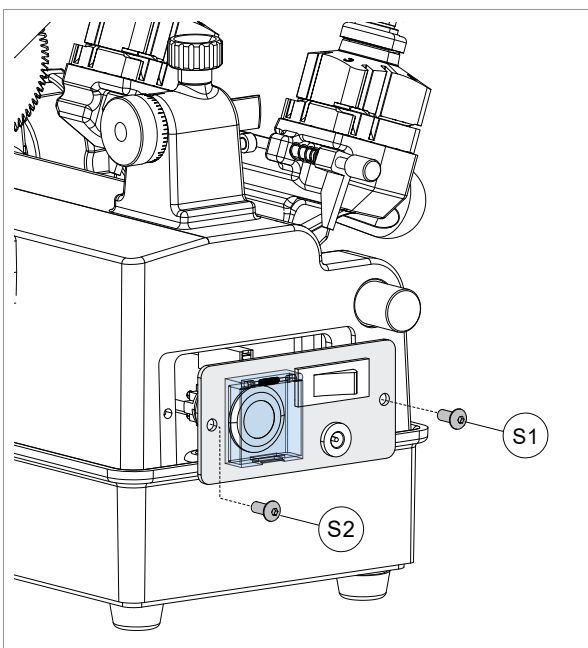

Fig. 42

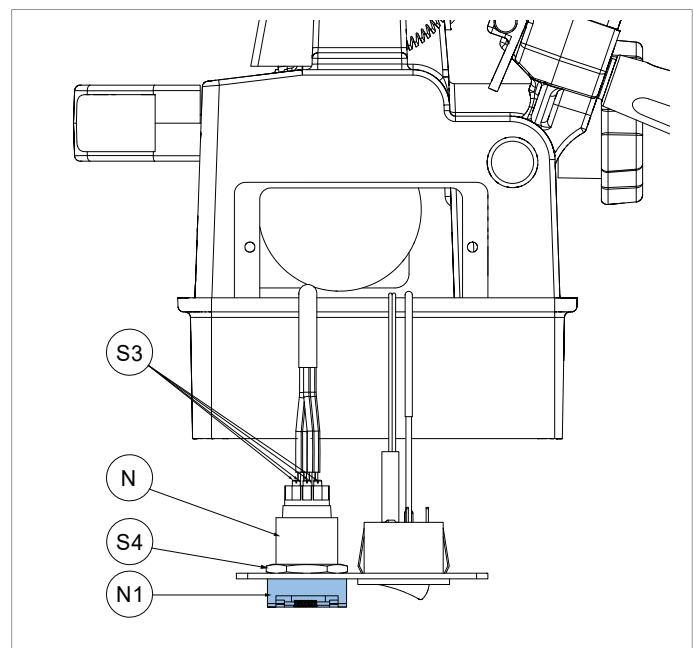

Fig. 43

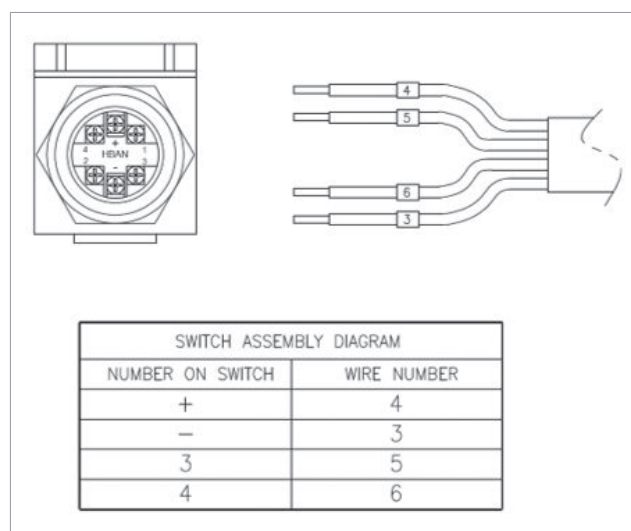

Fig. 44

6.8 Replacing the motor start switch

⚠ ATTENTION: turn off the machine with motor switch (T), turn off main power switch (N), close the switch protection cover (N1) and check that it is NOT connected to the battery.

- 1) Please refer to chap.6.6 to access the lower compartment and disconnect the battery connection.
- 2) Place the machine in upright position and unscrew (S1) and (S2) screws to open the plate, as shown in Fig. 45.
- 3) Disconnect connector (T1) (Fig. 46).
- 4) Remove switch (T) by pressing tabs with a screwdriver (Fig. 47 - Fig. 48).
- 5) Insert the new switch.
- 6) Reconnect connector (T1).
- 7) Please tight screws (S1) and (S2) to assemble the plate.
- 8) Connect the battery connection and close the lower compartment.

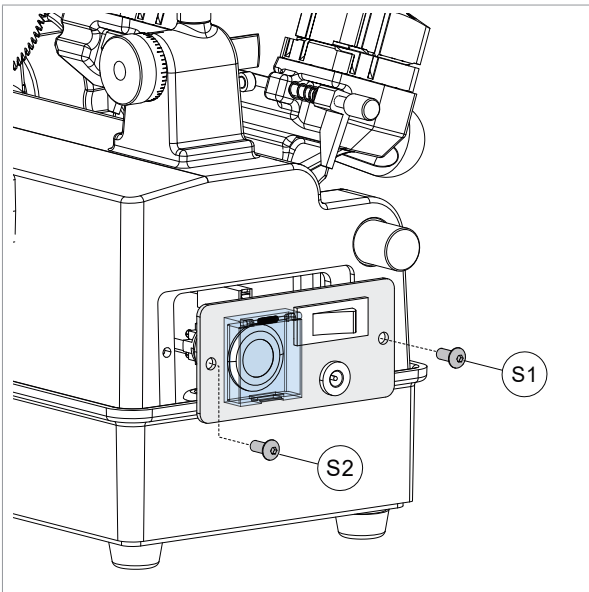

Fig. 45

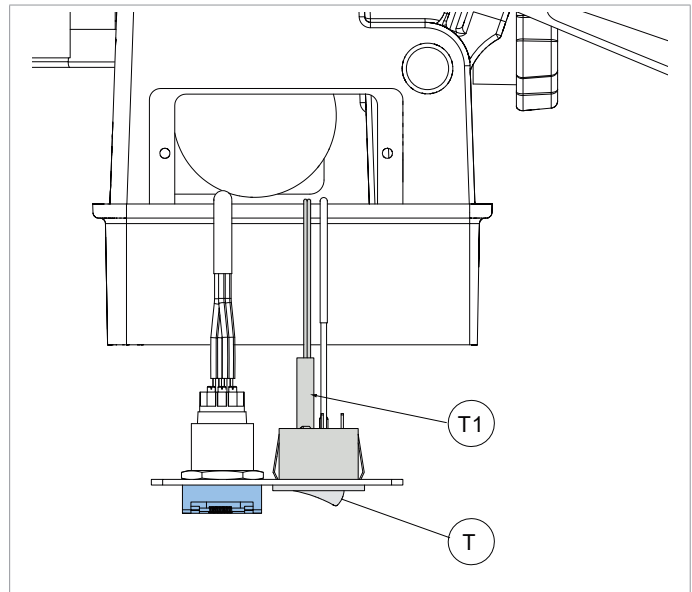

Fig. 46

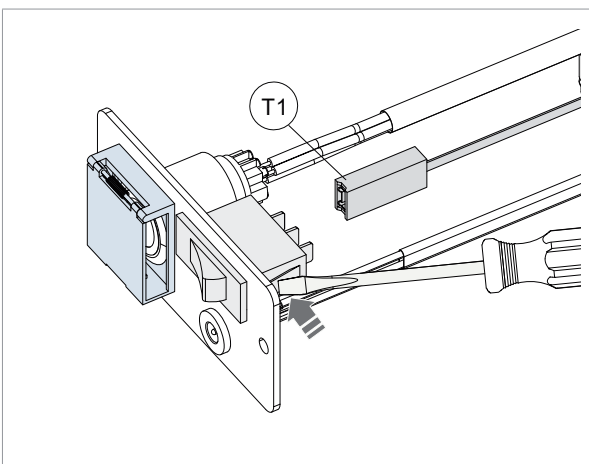

Fig. 47

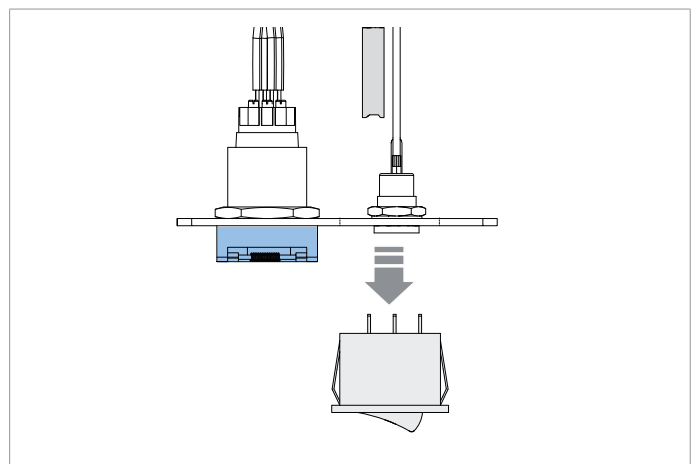

Fig. 48

6.9 Replacing and/or adjusting tension on the belt

Worn or loose belts must be replaced or adjusted so as to ensure safe and proper operation of the cutting tool/brush.

⚠ ATTENTION: turn off the machine with motor switch (T), turn off main power switch (N), close the switch protection cover (N1) and check that it is NOT connected to the battery.

- 1) Remove the cover (L) by loosening the 3 screws (L1) (Fig. 49).
- 2) Remove the handle (P) after removal of the 2 screws (P1) (Fig. 50).
- 3) Loosen the 4 motor fixing screws (W1) (Fig. 50).
- 4) Access the lower compartment (see chap.6.5).
- 5) Push the motor towards cutting tool and remove the worn belt.
- 6) Fit the new belt.
- 7) Pull the motor towards the machine bottom until the belt has the right tension (Fig. 51). Tighten the 4 screws (W1).
- 8) Place the bottom plate.
- 9) Return the machine to its upright position.
- 10) Refit the handle (P) and the cutter cover (L).

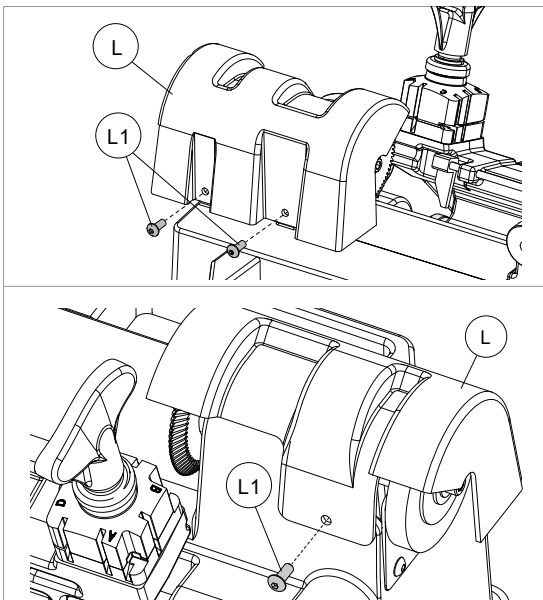

Fig. 49

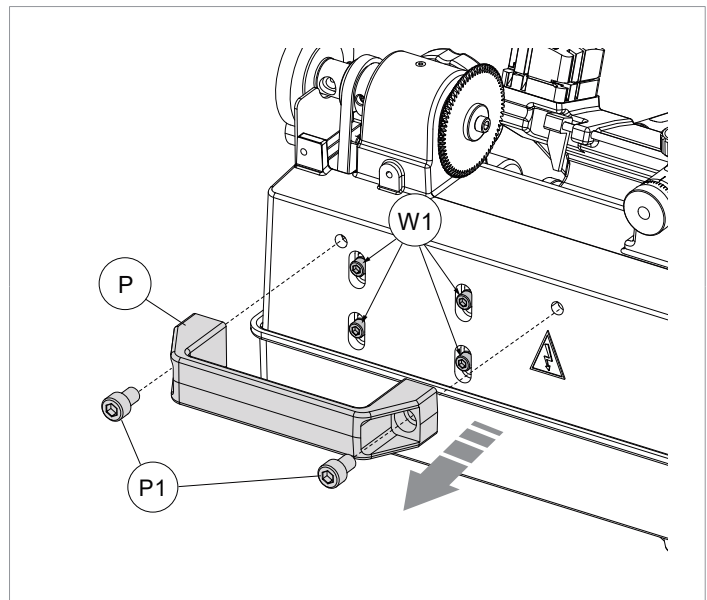

Fig. 50

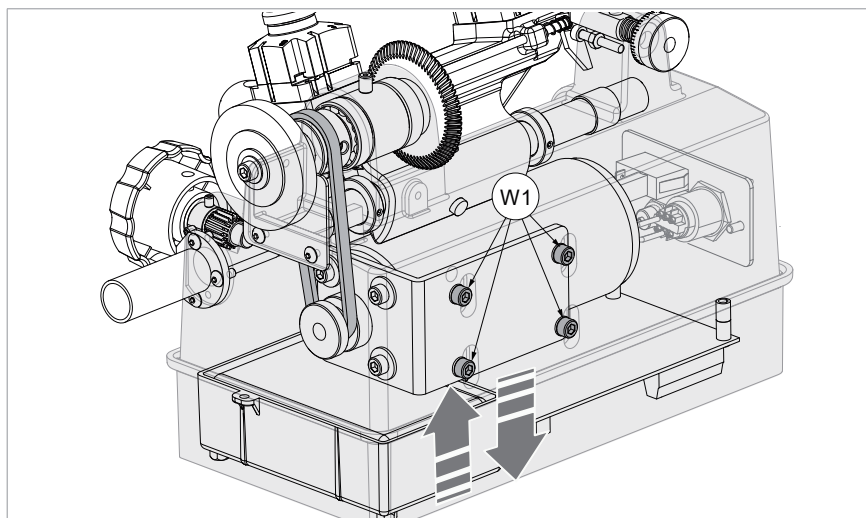

Fig. 51

7 DISPOSAL

For correct disposal please refer to current standards legal & statutory requirement of local country.

INFORMATION FOR USERS OF PROFESSIONAL EQUIPMENT



From “Actuation of Directive 2012/19/EU regarding Waste Electrical and Electronic Equipment (WEEE)”

The symbol of a crossed waste bin found on equipment or its packing indicates that at the end of the product's useful life it must be collected separately from other waste so that it can be properly treated and recycled.

In particular, separate collection of this professional equipment when no longer in use is organised and managed:

- a) directly by the user when the equipment was placed on the market before 31 December 2010 and the user personally decides to eliminate it without replacing it with new equivalent equipment designed for the same use;
- b) by the manufacturer, that is to say the subject which was the first to introduce and market new equipment that replaces previous equipment, when the user decides to eliminate equipment placed on the market before 31 December 2010 at the end of its useful life and replace it with an equivalent product designed for the same use. In this latter case the user may ask the manufacturer to collect the existing equipment;
- c) by the manufacturer, that is to say the subject which was the first to introduce and market new equipment that replaces previous equipment, if it was placed on the market after 31 December 2010;

With reference to portable batteries/accumulators, when such products are no longer in use the user shall take them to suitable authorised waste treatment facilities.

Suitable separate collection for the purpose of forwarding discarded equipment and batteries/accumulators for recycling, treatment or disposal in an environmentally friendly way helps to avoid possible negative effects on the environment and human health and encourages re-use and/or recycling of the materials making up the equipment.

To remove batteries/accumulators, consult the manufacturer's specific instructions: (see relevant chapter in the users' manual)

The sanctions currently provided for by law shall apply to users who dispose of equipment, batteries and accumulators in unauthorised ways.

8 ASSISTANCE

Silca provides full assistance to purchasers of the key-cutting machine. To ensure complete safety for the operator, any job not specified in this manual should be carried out by the manufacturer or in the special Service Centres recommended by Silca.

At the end of the manual there is a list of manufacturers' and authorized Service Centre addresses; if the manual was downloaded it's necessary visit the website to see the contacts (www.silca.biz).

8.1 How to request service

The guarantee attached to the key-cutting machines ensures free repairs or replacements of faulty parts within 24 months of purchase. All other service calls must be arranged by the customer with Silca or with a Silca service centre.



EU DECLARATION OF MACHINE COMPLIANCE

**SILCA S.p.A. - VIA PODGORA 20 (Z.I.)
31029 VITTORIO VENETO (TV) - (ITALY)
TEL. 0438 9136 - FAX. 0438 913800**

Declares under its own responsibility that the **Key-Cutting Machine** model

FLASH MOBILE

comply with the requirements of the following European Directives:

European Union **DIRECTIVE 2006/42/EC** (Machines)
European Union **DIRECTIVE 2014/30/EU** (Electromagnetic Compatibility)
European Union **DIRECTIVE 2014/35/EU** (Low Voltage)
European Union **DIRECTIVE 2011/65/EU** (RoHS2)
European Union **DIRECTIVE 2012/19/EU** (WEEE)

| 21 |

and with the following Standards:

EN ISO 12100:2010
EN 60204-1:2018
IEC EN 60034-1:2010
EN 61000-6-1:2007
EN 61000-6-3:2007 + A1:2011

Silca S.p.A. R&D Division is authorized to create a Technical File.

VITTORIO VENETO, 15/06/2021

CEO, Gazzola Michele