

## MATERIAL SPECIFICATION & INSTALLATION GUIDE

### PRODUCT ITEM CODE & DESCRIPTION

#### **ML 605 AS-N ~ STAINLESS STEEL, 1.2L LIQUID VERTICAL SOAP DISPENSER**

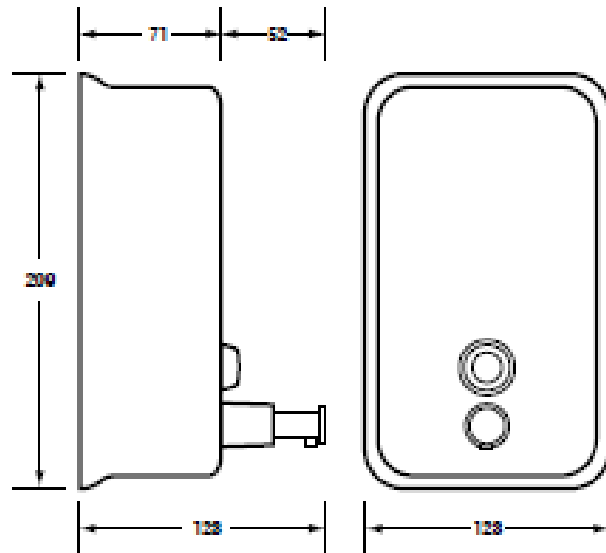

#### **MATERIAL SPECIFICATIONS:**

#304 Grade Stainless Steel body & mounting bracket - # Satin Stainless Steel (SSS) Finish Features: Anti-corrosion internal nylon lining, pump action soap dispenser, Impact resistant liquid level indicator and lockable hinged lid (key provided).

#### **DIMENSIONS:**

Overall ~ 123mm W x 209mm H x 123mm D [Includes 52mm Soap Valve Stand-off]

#### **INSTALLATION GUIDE:**

1. May be subject to Australian Building Code Regulations for height/location fixing and/or subject to placement as per architectural drawings, which in all cases is the responsibility of the installer re compliance.
2. Unit is provided with separate mounting bracket
3. Remove wall mount bracket, locate height on wall and mark using fixing holes on wall plate, ensuring unit is level and even. Measure/Check Twice ... Drill Once
4. Drill holes, loosely secure bracket to wall surface using appropriate screws/wall-plugs
5. Check level and tighten fasteners, then locate dispenser onto bracket, pushing down to lock into place.

**NOTE: The recommended liquid soap (not included) must be either coconut or vegetable oil based and have a neutral Ph (6.5-.9.0) to ensure correct function and operational longevity of the unit, plus compliance to warranty conditions. Please refer to Metlam Australia Consumable Advice Guide for this product for more information about suitable liquid soap options- [www.metlam.com.au](http://www.metlam.com.au)**

To ensure long term functionality, regular maintenance should be carried out and is the responsibility of the property owner / cleaning staff.

*These units should only be installed by a competent tradesperson and Metlam Australia takes no responsibility for any damage to walls or fixtures due to incorrect installation.*

The photographs and line drawings of the products presented above are representational only.  
Metlam Australia Pty Ltd reserves the right to, and from time to time, make changes and improvements in design and dimensions.