

# Parts List, Installation and General Information

## BL4409 ECP

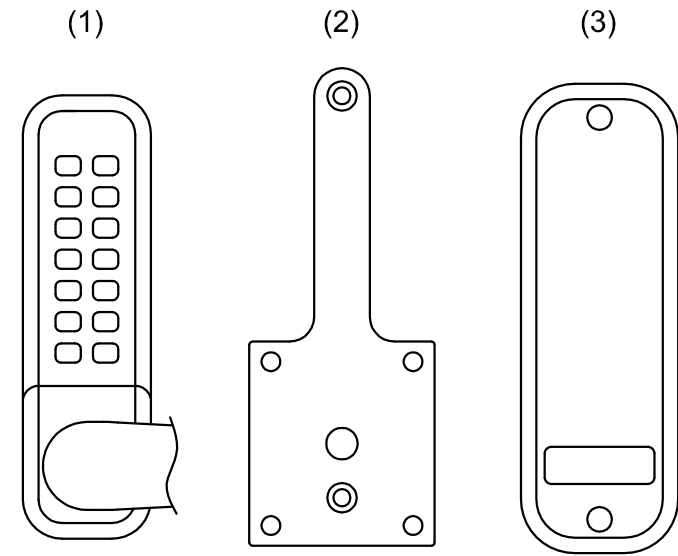

## Parts List

Please make sure you have received all the following parts:

- (1) Keypad.
- (2) Slam latch support plate.
- (3) Neoprene seals.
- (4) Spindles.
- (5) Slam latch.
- (6) Strike plate (Mortice).
- (7) Strike plate (Rim).
- (8) Fixing bolts x 4 (Use with slam latch).
- (9) Deactivating on door code change plug (x1)
- (10) Wood screws x 2 (Use with strike plate).
- (11) Fixingbolts x 3.
- (12) Code Change Key
- (13) Hex Key
- (14) Code Card

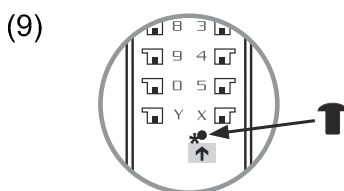
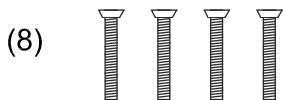
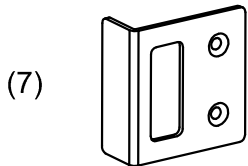
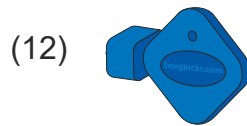
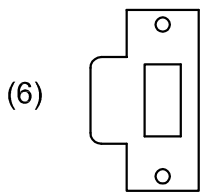
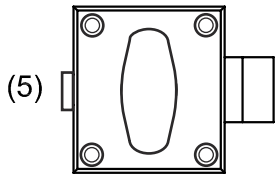
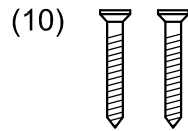
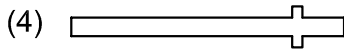

# Installation

## Special note

- Before commencing installation check that all parts are working correctly: Press the code according to the code card and then the knob should turn and return easily under spring pressure. If you intend to change the code, you should do it before installing the lock – See the code change instructions (opposite)
- Make sure that the inside handle moves freely. Check that the snib will engage and hold the handle in the 'latch - open' position, (holdback models Only)

Check that the latch bolt moves freely by pressing at the end and also by turning the flat spindle in the latch cam.

## 1. Determine your door type

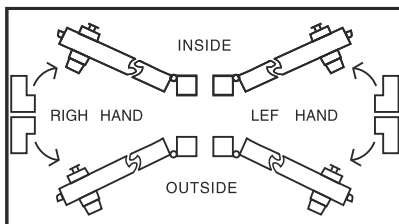

Your door is right-handed, if viewed from the outside, the hinges are on the right.

When fitting to a left-hand door, remove the rubber grommet from the base of the handle and remove the exposed grub screw.

Lift the handle off, turn it 180° and slide back. (Refit the grub screw and grommet).

## 2. Apply the template

Tape the template to the door, make sure that you fold it along the line

Mark and drill 2 10mm holes and 1 13mm holes.

## 3. Position and fix the slam latch, support plate and keypad

Hold the keypad with its gasket and slam latch support plate in position and with the fixing screws supplied secure to the door

## 4. Position the spindle

Locate the spindle in the back of the keypad, ensuring that it engages with the latch correctly dependant on the hand of the door

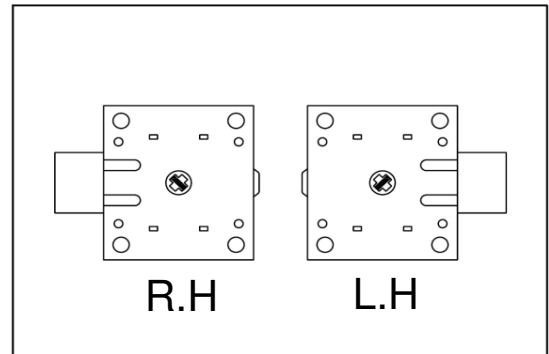

## 5. Fix the slam latch

Using the fixing bolts supplied fix the slam latch to the slam latch support plate

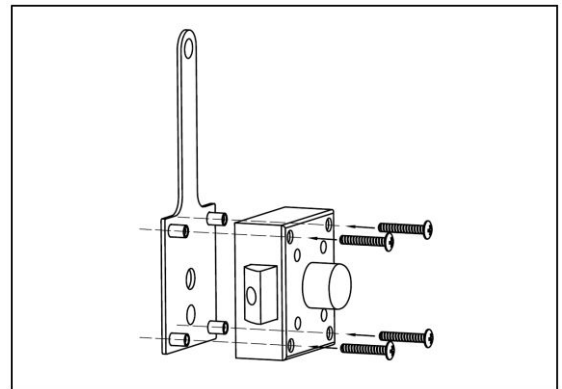

## 6. Fit the strike plate. Mortice

Position the strike plate on the door edge so that it lines up with the latch bolt.

Drill and cut a recess for the latch bolt.

Fit the strike plate using only one wood screw at first to ensure that it is positioned correctly.

When satisfied with its position secure the strike with the 2nd screw.

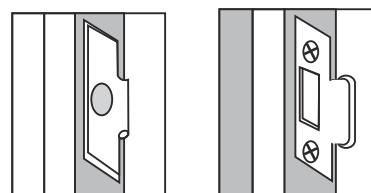

## 7. Fit the strike plate. Rim

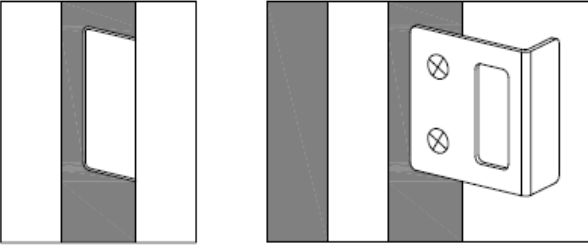

Position the strike plate on the door frame or post so that it lines up with the latch bolt

Mark the door for the correct screw fixing position

If necessary cut a recess for the latch bolt

Once positioned and ready secure the strike to the door frame or post with the fixing screws provided

## 8. How to change the hand of the Slam Latch

The latch bolt is reversible.

It is held in position with a internal hex screw.

Loosen the hex screw with a hex key and this will allow you to rotate the latch bolt 180° converting it from one hand to the other.

## 9. How to change code

The code should be changed with the door/gate in the open position. To change the code you will need to know what the keypad is currently set to. The code can be changed with the unit fitted on/off the door.

1. Enter existing code

2. Using code change key - insert into the hole in the \* button - **fully press and hold until step 5.**

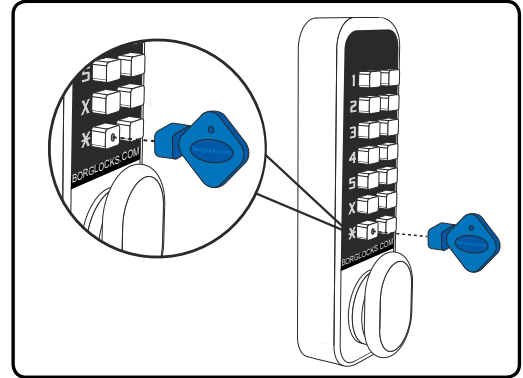

3. Press `C` button to clear the existing code.

4. Enter the new code.

5. Release the code change key from the hole in the \* button.

6. Press `C` to set the new code.

7. The new code is now set and ready for use

8. Check that the code is working 5 times and that it is withdrawing the latchbolt before closing the door/gate.

**Please note: If a mistake is made whilst entering a new code (with the \* button pressed) the `C` button can be pressed which will cancel any buttons that have been pressed and you can start again.**

If you experience any problems when fitting this lock or changing the code please contact the:

**BORG HELPLINE**  
**+44 (0)1708 225700**

Dismantling the lock will invalidate your warranty

# Problem Solving Guide

## Installation Problems

Problems	Cause	Solution
The latch cannot be withdrawn when entering the code	The lock has been fitted to a L.H. hung door.	All locks were set to suit R.H. Hung doors. So the lock needs to be removed from the door and reverse. Refer to instructions.
Both inside and outside knobs retract when turned towards the door frame.	The spindle is in position at the wrong angle	Remove the lock from the door, and re-position the spindle as shown in the instructions.
The knob will not turn after entering a new code.	One or more of the code tumblers are the wrong way around.	Re-read the code change instruction and check that the red tumblers are all facing with these square notches outwards.
The latch bolt does not move smoothly in and out.	The lock is not installed correctly.	Check that the lock is square on the door and positioned accurately over the latch, Check that the latch is positioned horizontally and parallel to door surfaces, Check the spindle length, it may be trapped between the front and backplate if the spindle is too long.
The outside knob turns after entering a correct code but does not retract latch.	The spindle is too short for the door thickness.	If the spindle is too short then it will not engage with both the outside knob and the inside handle at the same time, or it may slip out of one side after same use, If necessary, please call the helpline for a free replacement.

### After Installation Problems

Problems	Cause	Solutions
The outside knob turns freely with out retracting the bolt.	The knob has been forcibly turned.	Return the lock to Borg lock. Someone may have tried to force the knob to gain entry.
The inside lever handle does not return to the upright position after operating.	The lever return spring is broken.	Call the helpline for replacement.
The latch does not engage and so the door remains unlocked after use.	The latch is not entering the strike.	Your door or frame may have warped since the lock was installed. Check that the latchbolt is line up with the strike aperture, Re-align position of the strike as necessary. Make sure the deadlocking plunger does not enter the aperture alongside the latchbolt.

The Borg guarantee: If a Borg lock should develop a fault within 1 year from date of purchase we will repair it of charge.

Please call our helpline for spares, repairs and technical advice on +44 (0)1708 225700

**DISCLAIMER:** Under no circumstances should the lock be dismantled, this will invalidate our warranty.