

Magnetic Latch Installation Instructions

Magnetic Latch - Mortice Latch Body installation

Your **Adjustable Set Square, Automatic Centre Punch or Centre Punch** are essential to accurately mark out.



Decide whether you will be installing the Magnetic Latch body into the gate or post to best suit your application.

Apply painters tape to both the faces and edges of the gate and post at the required height to assist in marking out and reduce scratches.

1. Draw a **horizontal reference line 40mm** below the centre height of the digital flat spindle hardware lever onto both the faces and edges of the GATE and POST as ALL measurements come up from this **reference line**.
2. Draw a **vertical centreline** down the edge where the Magnetic Latch body is going to be installed.
3. Draw **vertical centrelines 25mm** in from the front edge down both faces for the Codelocks front and back plates.
4. Align the bottom of template provided with your **reference line** and your **vertical centrelines** for the body and Codelocks front and back plates.
5. Mark out the drilling locations with the template and then check measure before drilling pilot holes.
6. Drill pilot holes before the larger holes to help prevent your step drill or holesaw from movement.
7. File off the sharp points to allow the latch body to slide in place.

IMPORTANT!

Be sure to install the codepad locating pin to ensure correct codepad alignment with the Magnetic Latch body.

Only install the **Magnetic Strike plate** after the latch installation is complete.

Magnetic Strike Installation

1. Use the Template or come up **61mm** from the bottom reference line and mark a horizontal centreline which will be the centreline of the latch pin.
2. You will need to measure the exact location of how far in the centre of latch pin will sit after closing the gate/door.
3. Mark and centre the exact location.
4. Drill a pilot hole, then a 25mm hole.

5. Clean up all metal shavings before removing the Magnetic Strike Plate from the plastic bag for installation. Patented 2024204035. TRENCAB is a registered trademark. Australian owned, designed & manufactured.

The Magnetic Latch Mortice Latch Body and Magnetic Strike Plate are designed to be face fixed for external or internal metal or timber domestic or light commercial grade gates, doors, access panels etc.

1. The Magnetic Latch's Mortice Latch body and Strike Plate can be installed to the gate or post.
2. Choose flat spindle "Codelocks front and back plates" to suit your application.
3. The latch body has a 25mm backset measured from the rear of the faceplate.
4. Case depth is 46mm when surface mounted.
5. Face fixing will require a gap of 8mm between the posts. Magnetic Strike Plate depth is 21mm when surface mounted. 2 x 2.5mm Strike Plate Packers are included for larger gaps.
Note: 2.5mm Strike Plate Packers are also available as a spare part. (The Magnetic Latch Mortice Latch body and or Strike Plate can be flush fixed. You will need to make your own measurement adjustments).

IMPORTANT!

Keep the Magnetic Strike Plate inside the plastic bag to install last after all metal shaving are cleaned away as they will accumulate inside the magnetic strike plate cup.

DO NOT use power tools to attach the Magnetic Latch latch body or Magnetic Strike Plate.

DO NOT lubricate the Magnetic Latch Mortice Latch body. There are no serviceable components inside. Warranty will be void if latch case screws are removed or other fixing are used. The Magnetic Latch Mortice Latch **WILL NOT** act as device to stop a swinging gate or door. Suitable stopper must be installed.

DIMENSIONS

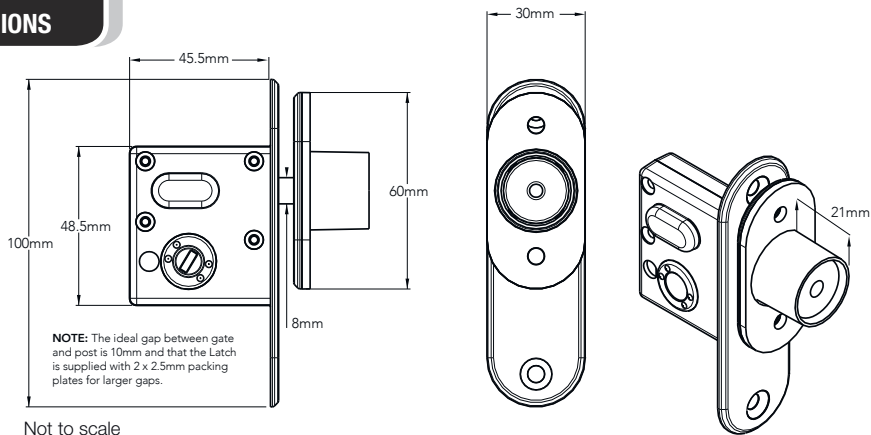

*Australian Made and Owned applies to the Magnetic Latch component only.

The Codelocks Control + Convenience logo and NetCode® are registered trademarks of Codelocks International Ltd, registered in the United Kingdom, United States and other countries and regions.

CODELOCKS
INTERNATIONAL LTD.

sales@codelocks.com
www.codelocks.com
Helpline, service & spares
Phone: 0800 393 405

CODELOCKS
EU B.V.

sales@codelocks.eu
www.codelocks.eu
Helpline, service & spares
Phone: +31 53 80 80 118

CODELOCKS
INC.

sales@codelocks.us
www.codelocks.us
Helpline, service & spares
Toll free: 1.877.codelock

CODELOCKS
(Australia) PTY LTD.

sales@codelocks.com.au
www.codelocks.com.au
Helpline, service & spares
Toll free: 1800 052 131

CODELOCKS
control + convenience

