

Magnetic Latch



Installation and Operating Instructions

TML25-DGT - Mortice Latch Body installation

Your **Adjustable Set Square, Automatic Centre Punch or Centre Punch** are your friend to accurately mark out.



Decide whether you will be installing the TML25-DGT latch body into the gate or post to best suit your application.

Apply painters tape to both the faces and edges of the gate and post at the required height to assist in marking out and reduce scratches.

1. Draw a **horizontal reference line 40mm** below the centre height of the Digital flat spindle hardware lever onto both the faces and edges of the GATE and POST as ALL measurements come up from this **reference line**.
2. Draw a **vertical centreline** down the edge where the TML25-DGT latch body is going to be installed.
3. Draw **vertical centrelines 25mm** in from the front edge down both faces for the Digital Hardware.
4. Align the bottom of template provided with your **reference line** and your **vertical centre lines** for the body and Digital Hardware.
5. Mark out the drilling locations with the template and then check measure before drilling pilot holes.
6. Drill pilot holes before the larger holes to help prevent your step drill or holesaw from wandering.
7. File off the sharp points to allow the latch body to slide in place.

IMPORTANT!

BE SURE TO INTALL THE CODEPAD LOCATING PIN TO ENSURE PROPER CODEPAD ALIGNMENT WITH THE TML25-DGT BODY.

ONLY INSTALL THE **MAGNETIC STRIKE PLATE** AFTER THE LATCH INSTALLATION IS COMPLETE.

Magnetic Strike Installation

1. Use the Template or come up **61mm** from the bottom reference line and mark a horizontal centre line which will be the centre line of the latch pin.
2. You will need to measure the exact location of how far in the centre of latch pin will sit after closing the gate/door.
3. Mark and centre pop the exact location.
4. Drill a pilot hole, then a 25mm.
5. Clean up all metal shavings before removing the Magnetic Strike Plate from the plastic bag for installation.

TRENCAB TML25-DGT Face Fixed Mortice Latch to suit flat spindle hardware



Patented 2024204035. TRENCAB is a registered trademark. Australian owned, designed & manufactured.

The TML25-DGT Mortice Latch Body and Magnetic Strike Plate are designed to be face fixed for external or internal metal or timber domestic or light commercial grade gates, doors, access panels etc.

1. The TML25-DGT Mortice Latch body and Strike Plate can be installed to the gate or post.
2. Choose flat spindle “Digital Hardware” to suit your application.
3. The latch body has a 25mm backset measured from the rear of the faceplate.
4. Case depth is 46mm when surface mounted.
5. Face fixing will require a gap of 8mm between the posts. Magnetic Strike Plate depth is 21mm when surface mounted.

2 x 2.5mm Strike Plate Packers are included for larger gaps.

Note: 2.5mm Strike Plate Packers are also available as a spare part. (The TML25-DGT Mortice Latch body and or Strike Plate could be flush fixed. You will need to make your own measurement adjustments)

IMPORTANT!

Keep the Magnetic Strike Plate inside the plastic bag to install last after all metal shaving are cleaned away as they will accumulate inside the magnetic strike plate cup.

DO NOT use power tools to attach the TML25-DGT latch body or magnetic strike plate.

DO NOT Lubricate the TML25-DGT Mortice Latch body. There are no serviceable components inside. Warranty will be void if latch case screws are removed or other fixing are used. The TML25-DGT Mortice Latch **WILL NOT** act as device to stop a swinging gate or door. Suitable stopper must be installed.

DIMENSIONS

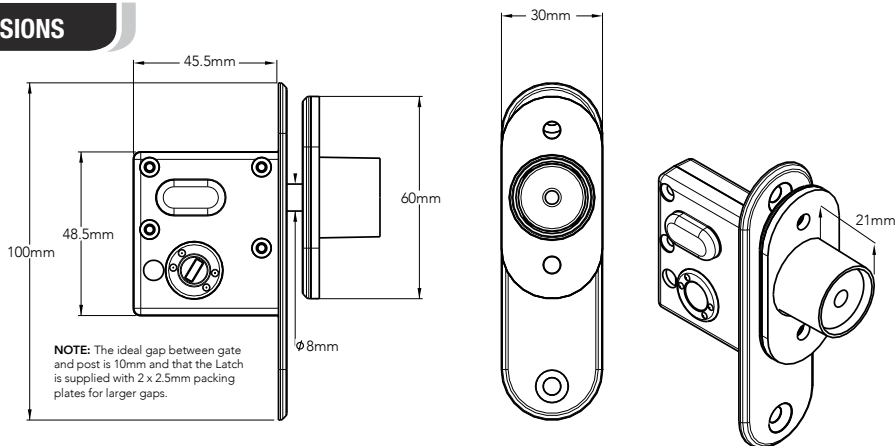

CODELOCKS INTERNATIONAL LTD.

sales@codelocks.com
www.codelocks.com
Helpline, service & spares
Phone: 0800 393 405

CODELOCKS EU B.V.

sales@codelocks.eu
www.codelocks.eu
Helpline, service & spares
Phone: +31 53 80 80 118

CODELOCKS INC. US

sales@codelocks.us
www.codelocks.us
Helpline, service & spares
Toll free: 1.877.codelock

CODELOCKS (Australia) PTY LTD

sales@codelocks.com.au
www.codelocks.com.au
Helpline, service & spares
Toll free: 1800 052 131